

Review of PID Optimization Methods Applied to Automatic Voltage Regulators

Dr. Sunil V. More, Miss. Komal Patidar, Mr. Rajesh Pawar*

Department of Electrical Engineering, Shri Vaishnav Institute of Technology & Science, Indore, Madhya Pradesh, India

ABSTRACT

This paper presents on survey paper of PSO and automatic voltage regulator for synchronous generator. It is used to obtain for regulation and stability of any electrical equipment. There are many technology/methods were used in automatic voltage regulator as well as different controller used for improving robustness, overshoot, rise time and voltage control but problem is about to survey on Automatic Voltage Regulator. Comparisons studies which are based on PID Controller are performed to show rise time, overshoot, and undershoot according to different research paper analysis.

KEYWORDS: AVR system, Particle Swarm Optimization (PSO), GA, PID Controller, etc.

INTRODUCTION

The main function of an AVR system is to hold the magnitude of terminal voltage of a synchronous generator at a specified level. Thus, the stability of the AVR system would seriously affected the security of the power system. The Proportional integral Derivative (PID) [1] controller is chosen compared to other controllers because of its uncomplicated and robust behaviour. A simple AVR consist of amplifier, exciter, generator and sensor. The block diagram of AVR with PID controller is shown in Figure 1[14].The step response of this system without control has oscillation which will reduce the performance of the regulation. Thus, a control technique must be applied to the AVR system. For this reason, the PID block is connected in series with amplifier. Several tuning methods have been proposed for the tuning of control loop.

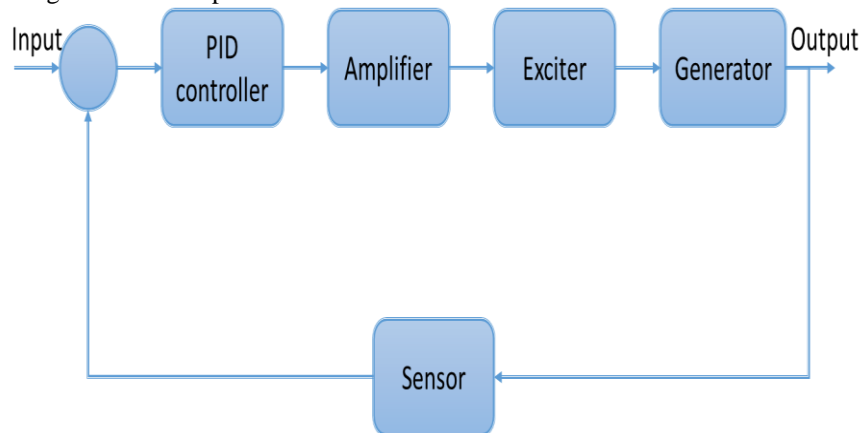

Fig: 1 Block Diagram of AVR with PID

This Paper presents a tuning method based on evolutionary computing approach to determine the PID (proportional-Integral-Derivative) controller parameters in Automatic Voltage Regulator (AVR). The main objective is to increase the step response characteristics and reduce the transient response of AVR systems. In this paper described in deferent optimization method to determine the optimal PID controller parameters of an AVR system.

Automatic Voltage Regulator

Automatic voltage regulators are used to control generators output. An AVR consists of diodes, capacitors, resistors and potentiometers or even microcontrollers, all placed on a circuit board. This is then mounted near the generator and connected with wires to measure and adjust the generator. The AVR maintain output voltage and control input voltage for exciter of generator. In figure: 1 automatic voltage regulator block diagram and combinations of blocks like PID Controller, Amplifier, exciter, generator and a sensor is connected in feedback of above blocks.

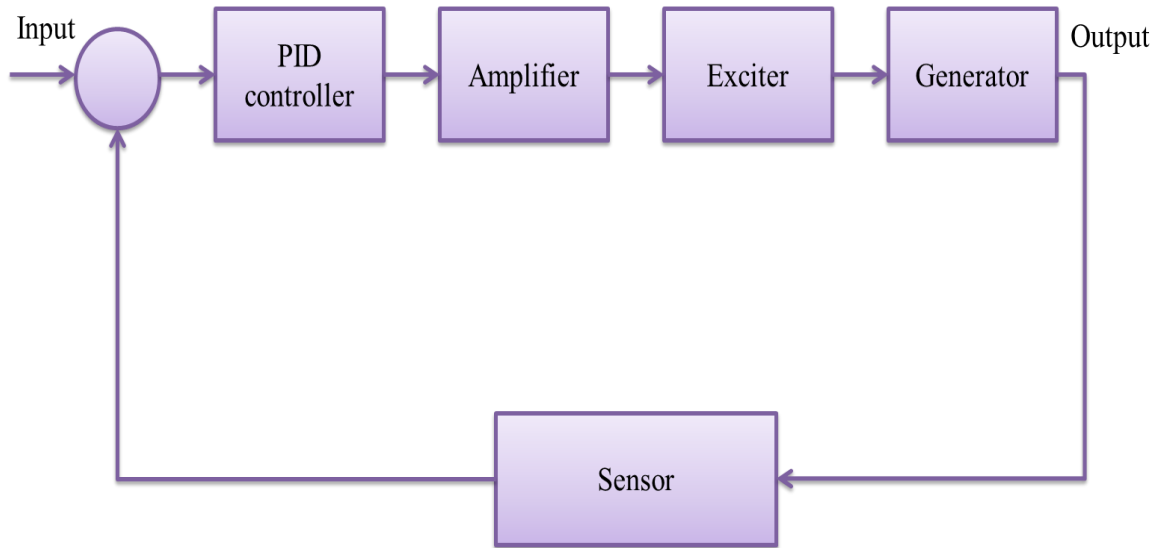

Fig: 1 Automatic Voltage Regulator

Many researchers are worked in the design and optimized of the AVR. The objective is to maintain the terminal voltage as a constant at the operating points. The main requirements for designing the AVR are fast response, small overshoot and zero steady-state error to the deviation of the reference voltage [6].

RELATED WORK

Snigdha Priyambada et.al, [1], study in this paper, the analysis of Automatic Voltage Regulator (AVR) using proportional-integral-derivative controller optimized by Teaching Learning Based Optimization method. The optimum gain of the controller for the proposed model is obtained with objective function as Integral Time Absolute Error. Performance of the system is found to be better in every aspect in terms of the settling point, peak overshoot. The transient response analysis and robustness analysis of the AVR system tuned by TLBO algorithm is documented profitably.

Leandro dos Santos Coelho, [2], in this paper, a tuning method for determining the parameters of PID control for an automatic regulator voltage (AVR) system using a chaotic optimization approach based on Lozi map is proposed. Since chaotic mapping enjoys certainty, ergodicity and the stochastic property, the proposed chaotic optimization introduces chaos mapping using Lozi map chaotic sequences which increases its convergence rate and resulting precision. The COLM methodologies were successfully validated for tuning of PID controller for the AVR system about six different operational conditions. From the case studies and comparison of the results through five tested COLM approaches, it has been show that the parameter of step size k is essential to the good convergence profile. In this context, the parameter k regulates the trade-off between the global and local exploration abilities of the chaotic local search. However, in future works will include a detailed study of self-adaptive heuristics for the step size design.

G. Madasamy, et.al, [3], investigate in this paper, design and tuning of PID for Automatic Voltage Regulator system to improve the dynamic performance and robustness of the system. The PID controller is the very commonly used compensating controller which is used in higher order method. This controller widely used in many different areas like Chemical process control, Aerospace, Automation and Electrical Drives and other. Tuning of PID parameters is important because, parameters have a great effect on the stability and performance of the control system. Bacterial Foraging Optimization techniques is one of the important techniques to tune the PID parameter in AVR technique. Numerical solution based on the proposed PID control of an Automatic Voltage Regulator for nominal system parameters and step reference of voltage input validates the good performance. The objective function of the proposed Bacterial Foraging Optimization algorithm is designed according to the required control characteristics of AVR. The proposed Bacterial Foraging Optimization tuning method has better performance compared with the conventional ZN tuning method. The results of the simulating Automatic Voltage Regulator scheme is proved to be better than the tuning the controller after approximation or by any traditional existing methods.

Hwan Il Kang, et.al, [4], study in this paper, PID controller design methods for automatic voltage regulators. We use three improved particle swarm optimization for PID controllers with which the step response is optimally regulated for automatic voltage controllers. We compare three different versions of particle swarm optimizations, the modified original PSO, the crazy PSO and the chaotic PSO. The chaotic PSO has best performance than the other two PSOs with respect to the output of the AVR and the convergence results. With the chaotic PSO, the convergence rate is fastest and stable. In future work, we will study design of fractional order PID controllers using the chaotic PSO.

CONCLUSION

This paper also investigates of Automatic Voltage Regulator technique, PSO and other method. This paper presents a survey of the work published on the application of various optimization techniques applied to solve the problems of automatic voltage regulator system. In various optimization techniques that tackled the problem are overviewed and classified with their advantages and limitations critically discussed. In this paper, an evolutionary computing approach for determining the optimal values of the PID controller has been studied and presented in this paper.

REFERENCES

- [1] Snigdha Priyambada, Pradeep Kumar Mohanty, Binod Kumar Sahu “Automatic Voltage Regulator Using TLBO Algorithm Optimized PID Controller”, 2014.
- [2] Leandro dos Santos Coelho, “Tuning of PID controller for an automatic regulator voltage system using chaotic optimization approach”, Elsevier, 2014.
- [3] G. Madasamy, C. S. Ravichandran, “PID Controller Tuning Optimization with BFO Algorithm in AVR System”, International Journal on Recent and Innovation Trends in Computing and Communication, Volume: 2 Issue: 12, December 2014.
- [4] Hwan Il Kang, Min Woo Kwon, Hwan Gil Bae, “Comparative Study of PID Controller Designs Using Particle Swarm Optimizations for Automatic Voltage Regulators”, IEEE, 2011.
- [5] A. P. Engelbrecht, Fundamentals of Computational swarm intelligence, Chichester, West Sussex, U.K., John Wiley & Sons, 2005.
- [6] V. Mukherjee and S. P. Ghoshal, “Intelligent particle swarm optimized fuzzy PID controller for AVR system,” Electric Power Systems and Research, 2007.
- [7] Dong Hwa Kim, “Hybrid GA-BF based intelligent PID controller tuning for AVR system,” Applied Soft Computing Journal, 2009.
- [8] L. S. Coelho, “Tuning of PID controller for an automatic regulator voltage system using chaotic optimization approach,” Chaos, Solitons and Fractals, vol. 39, no. 4, 2009.