

Development of a Smart Security System Based on Digital Image Processing

K. Sravani*, Dr. B. Ramana Rao

* M.Tech, ECE Department, D.M.S.S.V.H. College of Engineering, Machilipatnam-521002, India
Professor, ECE Department, P.V.P. Siddhartha Institute of Technology, Vijayawada, India

ABSTRACT

Now a days, security systems are meant only for the purpose of recording the images like cc cameras or for giving some alerts to the security officers about the theft. But, they won't take any action on the thief during the theft. This problem may be overcome by employing the enhanced security provided by the "INTELLIGENT SECURITY SYSTEM", without any manual assistance. It will take the action directly on the thief during the theft in a fraction of seconds. Intelligent Security Systems are employed mainly for the MILITARY ROBOTS to fight with the enemy person by automatically turning to the direction of the enemy and firing at him. They are also applicable in the MUSEUMS for high security.

INTRODUCTION

Image Processing is a technique to enhance raw images received from cameras/sensors placed on satellites, space probes and aircrafts or pictures taken in normal day-to-day life for various applications.

Various techniques have been developed in Image Processing during the last four to five decades. Most of the techniques are developed for enhancing images obtained from unmanned spacecrafts, space probes and military reconnaissance flights. Image Processing systems are becoming popular due to easy availability of powerful personnel computers, large size memory devices, graphics software etc.

An image acquisition device can be a video camera, which is used for capturing images. The image captured either with the help of digital or analogue cameras can be used as the input. Digital cameras like CCD or CMOS sensor are those which have the direct connection with the PC using USB port. In MATLAB, Augmented Reality is currently used for capturing the live video streams of the real world. It is directly interfaced with the PC (Image Processor), and MATLAB uses inbuilt software called adaptors for accessing or communicating with this device.

Image analysis can be done by extracting some of the functional details from the captured images. Therefore, if there is a requirement for identifying an object, then several robust characteristics of an object like color, pattern, edges, intensity, and structure must be noted.

Intelligent Security System operation is based on both image processing and the embedded system i.e., it employs a microcontroller which is programmed for control applications. In this System, a camera is made to focus on the particular image. The camera captures that image frequently and continuously at defined time intervals. These captured images are given as input to the MATLAB software. Then, MATLAB program compares the captured images with the initial image which is already stored in the system. The result of the MATLAB program is the position of the unexpected object in the image and it will be given as input to the microcontroller. The microcontroller rotates the motors horizontally and vertically to target that unexpected object by focusing a laser beam on its exact position.

PROPOSED BLOCK DIAGRAM

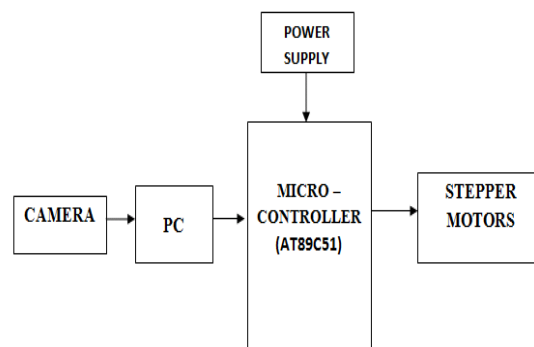

Figure: 1 Proposed block diagram of intelligent security system.

Intelligent security system provides the security by taking the direct action by targeting the unexpected object detected in an image during recording. The action taken by this system is done automatically within a fraction of seconds. Initially a camera is made to monitor the image that is to be protected. That camera captures the image at regular intervals of time. That captured images are sent to the matlab software in the pc for the image analysis. The first captured image is given as input to the matlab software and it will be considered as the original image. The captured images after the first image are compared with the original image regularly.

The output of pc will be given as input to the microcontroller. If the two images (the original image and the captured image) are same, then stepper motors remain in the same position. If there exist any difference between the two images or if the unexpected object arrives then, that difference pixel value will be given as input to the microcontroller. Microcontroller rotates the stepper motors in the direction of the exact position of the unexpected object. A laser light is made to focus the exact position the unexpected object. If the position of the unexpected object in the image changes then, the direction of the rotation of stepper motors also changes and the laser light is focused on that object.

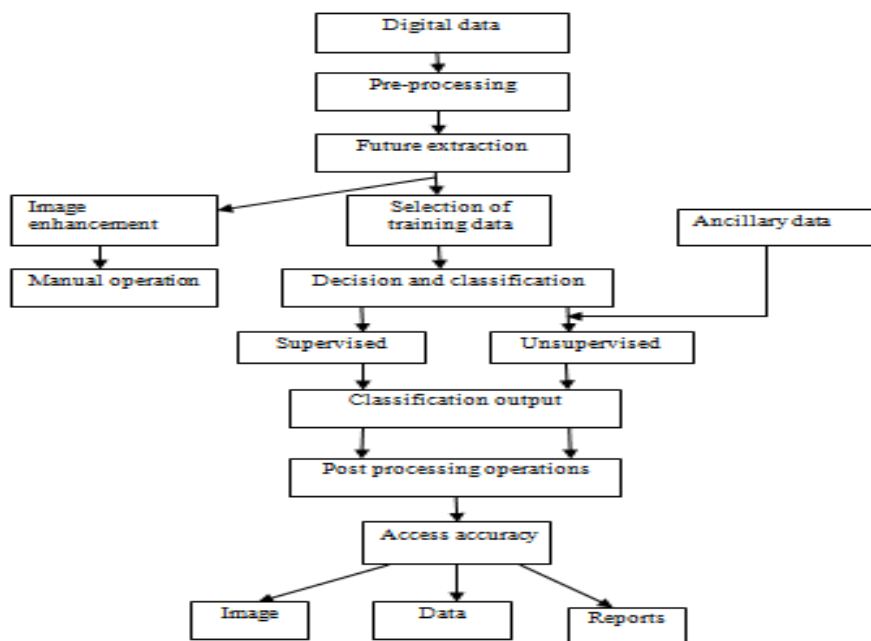

Figure: 2 Flow chart of image processing steps

WORKING OF INTELLIGENT SECURITY SYSTEM (ISS)

Intelligent security system working is based on the both image processing and embedded systems concepts. Image processing concept is used in the process of capturing the image and the embedded system concept used in the programming of microcontroller using c language.

Step-1

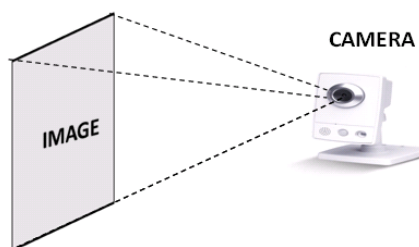

Figure 3: working of ISS in step1

Initially a camera is made to monitor the particular image that is to be secured.

Step -2

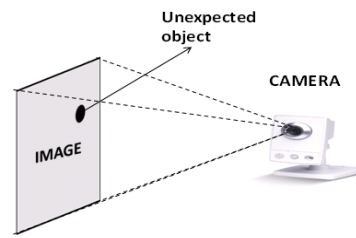

Figure 4: working of ISS in step 2

Camera detects the unexpected object (target) arrived in the image under monitoring.

Step-3

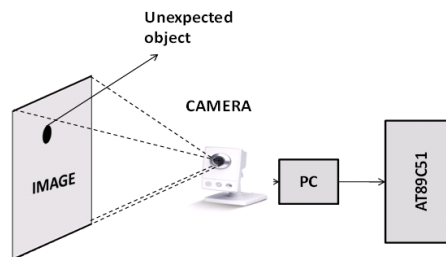

Figure 5: working of ISS in step 3

Camera focuses that unexpected object and gives this image as input to the Matlab software which process the input and gives the results to the microcontroller.

Step-4

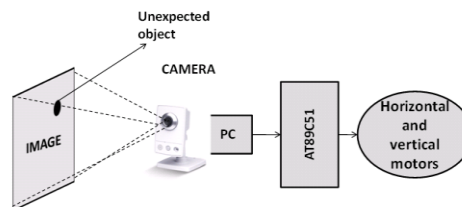

Figure 4: working of ISS in step 4

Microcontroller rotates the motors horizontally and vertically in the direction to detect the exact position of that unexpected object.

CONCLUSION

As a result intelligent security system using image processing detects the unexpected object in the image that is under high security and it can take the direct action on the unexpected object with in a fraction of seconds.

REFERENCES

- [1] A.KRAY, K.M.BHURCHANDI "Advanced Microprocessors And Peripherals", Tata Mc Graw Hill Publications.
- [2] AJAY.VDESHNUKH, "Microcontrollers", Tata Mc Graw Hill Publications.
- [3] KRISHNAKANTH, "Microprocessor &Microcontrollers" PHI Publications.
- [4] SHIBU.K.V-TATA "Introduction To The Embedded Systems " Mc Graw Hill Publications.