

Experimental Validation and Numerical Simulation of Condensation Prevention on Flipper Mullion in French door Refrigerators

Vikram Chauhan*, Ajay Yadav

* Department of Mechanical Engineering, Anurag Group of Institutions, Hyderabad, India

ABSTRACT

In French-style doors a flipper mullion is provided to have an air tight seal to avoid heat leakage between the doors. It is attached to one of the French doors through both of the hinge members. However, due to the complexity of the current concept, the outside surface of the flipper mullion remains in a cold temperature, presenting moisture. The moisture is unacceptable for aesthetic and safety reasons. A usual solution is to use a heater inside the flipper mullion (7 to 10W). The heater increases the temperature of the outside surface, avoiding the moisture formation. It increases the complexity of the assembly and the energy consumption. A 7W flipper mullion heater power corresponds to 5 kWh/ month, which means around 4% of the total energy consumption of regular French door refrigerators.

In the present study, an attempt has been made to reduce the external condensation by changing the material and the design of flipper mullion. Variation of flipper mullion external surface temperature with change in the material and design of flipper mullion are investigated to determine the economically viable concept.

KEYWORDS: French door refrigerators, flipper mullion, external condensation, external surface temperature.

INTRODUCTION

In French-style doors, a flipper mullion is provided to ensure an air tight seal which prevents heat leakage. It is attached to one of the French door through first and second hinge members. Each of the first and second hinge elements have corresponding cam members [8]. The cam members include multiple lobes and extend above the hinge pins that define an axis of rotation for the mullion as shown in figure 1, while the mullion is not required to “divide” the compartments, French-style doors require a central sealing surface. Stationary mullion bar fixed to the refrigerator will limit the size and shape of goods capable of being placed in the compartment, as well as the accessibility to the goods.

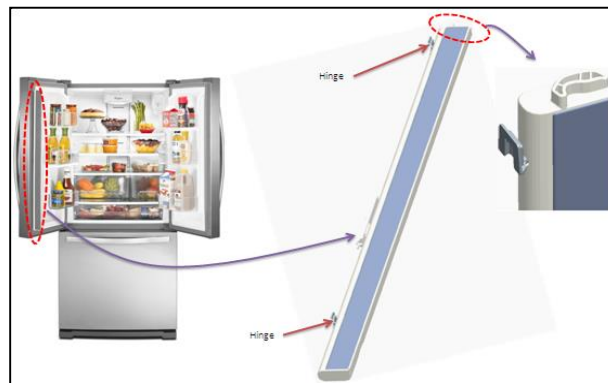

Fig:1 Refrigerator having French-style doors and a rotating mullion bar

Flipper mullion is carried by one of the two French-style doors. Typically, the mullion is caused to pivot when the door is opened or closed, with the mullion pivoting about hinge elements that allow the mullion to travel between first and second positions. Most designs include a locking mechanism, either in the form of a magnetic retaining element or a separate spring biased lock.

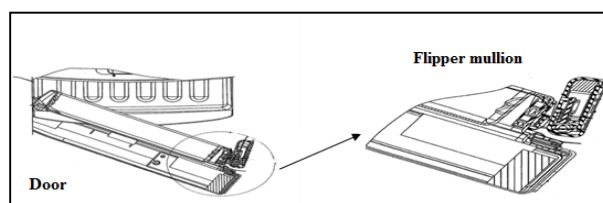

Fig:2 Flipper mullion attached to a door

Properties of flipper mullion

Flipper mullion cover is made of steel to stick onto gasket in which a magnetic strip is provided. Flipper mullion cover is provided to achieve a tight fit so that air leakages are avoided.

Table 1. Properties of Steel

STEEL(Flipper mullion cover)	Properties
Ferromagnetic	Permeability μ [H/m]= 1.26×10^{-4} (Magnetic field at 0.002 T)
Thermal conductivity	50 W/mk to 60 W/mK
Thickness	0.48mm
Width of collar	9.3 mm

Table 2 Properties of materials used for flipper mullion which is made of ABS Plastic

ABS (Flipper mullion)	Properties
Thermal conductivity	0.1 w/mk
Coefficient of thermal expansion(1/K)	0.00008
Thickness	2.54mm
Height of guider	10.4 mm

Table3. An insulation made of EPS

Insulation	
Density	40 kg/m ³
Thermal conductivity	0.04 W/mK
Thickness	19 mm
Height	987 mm

PROBLEM STATEMENT

Condensation on flipper mullion

The flipper mullion is used in order to close the gap between the doors and avoid air leakage. However, due to the complexity of the current concept, the outside surface of the flipper mullion remains in a cold temperature, presenting moisture. The moisture is unacceptable for aesthetic and safety reasons.

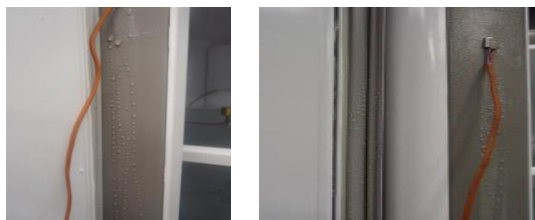

Fig: 3 Condensation on flipper mullion

The fig 3 shows two issues being faced

- i. External condensation at the flipper mullion surface and
- ii. External condensation at the gasket.

The condensation at the mullion surface is caused by the heat transfer through the plastic cover and EPS part. The condensation at the gasket occurs because of the internal air flow direction, which is supplied directly to the lateral sides of the mullion.

A usual solution is to use a heater inside the flipper mullion (7 to 10W). The heater increases the temperature of the outside surface, avoiding the moisture formation. It increases the complexity of the assembly and increase the energy consumption. A 7W power corresponds to 5 kWh/month, which means around 4% of the total energy consumption of a regular French door refrigerator.

OBJECTIVES

- 1. Improve aesthetics by ensuring no moisture formation.
- 2. Suggesting improvements to remove condensation and reduce heat leaks.
- 3. Reduction in power consumption by removal of mullion heater thus reducing the load on compressor.
- 4. Suggesting improved insulation of flipper mullion by analyzing various alternative available materials.

LITERATURE SURVEY

Thermal insulations

Insulations means using some materials as thermal insulation for reducing the heat transfer in the construction of insulated body. Thermal insulation will help to reduce unwanted heat loss and can decrease the energy demands of heating and cooling system. The effectiveness of insulation is commonly evaluated by the key property of a thermal insulation material—thermal conductivity k ($W/m\cdot K$), which refers to a material’s ability to conduct heat. As good insulation materials, it is needed to achieve as low thermal conductivity as possible, which enables, accordingly, a high thermal resistance as well as a low thermal transmittance.

Moreover, common insulation materials are characterized by light weight, small apparent density, loose and porous, which can barrier the thermal conductivity by the internal non-flow air. Among these, the inorganic insulation materials have non-flammability, a wide temperature range, good resistance to chemical corrosion while the organic materials have high intensity, low water absorption as well as good impermeability.

Rice husk has insulation

S. R. Bello, and T.A. Adegbulugbe [2] , they made a Comparative Study on Utilization of Rice husk alone Charcoal and Sawdust as an insulation material and reported that rice husk has better insulating properties in terms radiation and conduction losses with respective time.

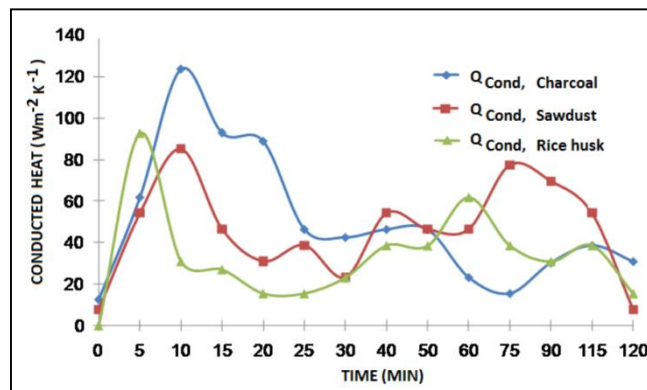

Fig: 4 Conducted heat Vs, Time

Comparison of the insulation materials

This below table has presented a survey of different thermal insulation materials components. With the knowledge of the basic heat transfer mechanisms and the ways to reduce the total thermal conductivity of a material or component, novel thermal insulation materials and components were described. Thermal conductivity is a property of a substance and characterise its ability to transfer heat by conduction. In general, the numerical value of thermal conductivity is highest for solids, the lowest for gases and it has intermediate values for liquids. A summary of the thermal Conductivity of the materials is presented.

Table 4. Thermal conductivity of insulating materials

Materials	Thermal conductivity (milliW/mK) at 10 °C	Density(kg/m ³)
Jute	35	50
sugarcane fiber	50	100
coconut fiber	55	50
Rice husk	22	400-600

Mathematical Modeling and Simulation Results

Determination of surface temperature of flipper mullion

Assumming one dimentional heat flow through flipper mullion, the major modes of heat tranfer are conduction and convention .The existing mullion is compared with two prototypes with varying insulation materials and different configurations.Surfaces temperatures obtained while using these are estimated assuming a one dimensional flow of heat.The resistances offered to transfer of heat through flipper mullion is represented in Fig 5.The conditions in ambient are (generally reported values) 305K, Relative humidity 85%, Convective heat transfer coefficient $h = 9 W/m^2\cdot K$.The conditions inside the Refrigerator chamber are 278K, convective heat transfer coefficient $h = 5 W/m^2\cdot K$. As flipper mullion is a composite slab $R_{mullion}$ varies with prototypes.

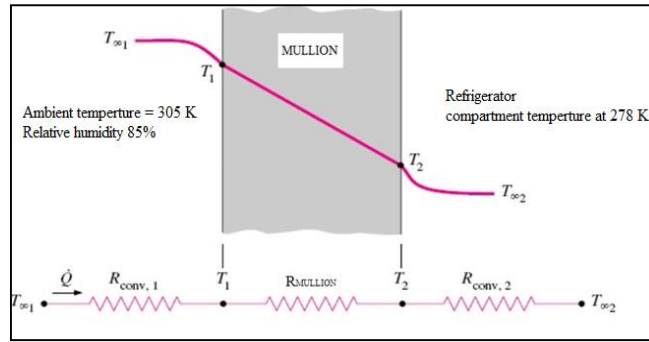

Fig: 5 Mullion as a one dimensional slab

Case 1:

This is an existing composition of Flipper mullion. Steel, Eps and Plastic (ABS) are different materials used in Flipper mullion. $R_{mullion}$ for this prototype is shown Fig along with convective resistances.

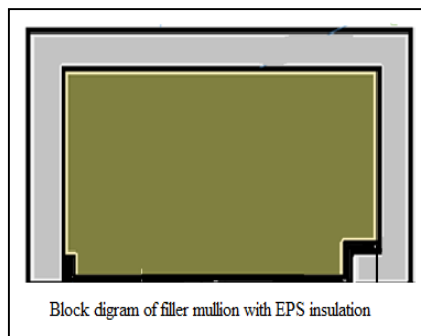

Fig: 6 Block diagram of flipper Mullion with EPS insulaton

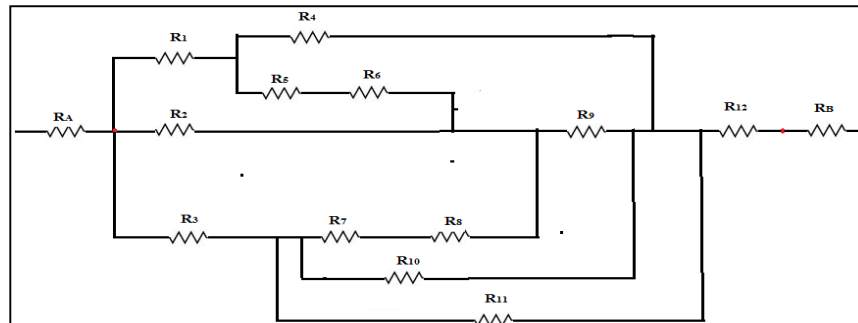

Fig: 7 Resistance circuit of existing Flipper Mullion

The various resistances as refferd to heat flow diagram are,

Table 5. List of resistances (case1)

R_A	Ambient convection	R_7	Plastic under steel edge
R_1	Plastic	R_8	Steel left
R_2	Steel surface	R_9	EPS Insulation
R_3	Plastic right side small edge	R_{10}	Plastic right side
R_4	Plastic left side small edge	R_{11}	EPS inside
R_5	Plastic under steel edge	R_{12}	Plastic surface
R_6	Steel right side edge	R_B	RC Convection

Case 2:

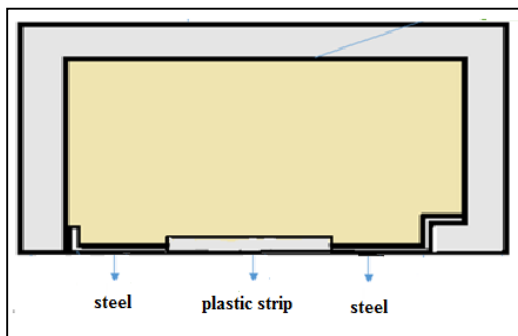

Fig: 8 Block diagram of Plastic strip Flipper Mullion Prototype

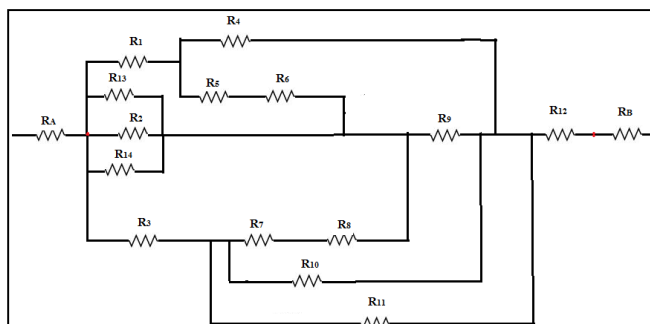

Fig: 9 Resistance circuit of plastic strip mullion

Table 6. List of resistances(case2)

R_A	Ambient convection	R_7	Plastic under steel edge
R_1	Plastic	R_8	Steel left
R_2	Plastic strip	R_9	EPS Insulation
R_3	Plastic right side small edge	R_{10}	Plastic right side
R_4	Plastic left side small edge	R_{11}	EPS inside
R_5	Plastic under steel edge	R_{12}	Plastic surface
R_6	Steel right side edge	R_B	RC Convection
R_{13}	Steel surface	R_{14}	Steel surface

Case 3:

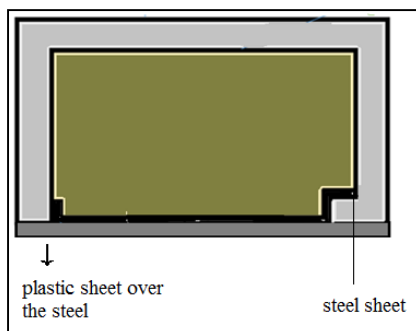

Fig: 10 Block diagram of plastic Coating steel

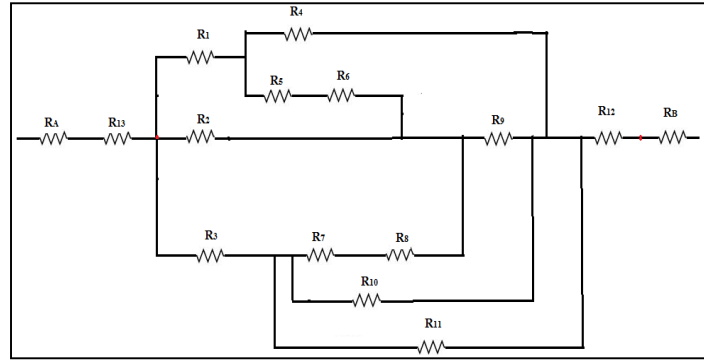

Fig: 11 Resistance circuit of plastic coated filler mullion

Table 7. List of resistances (case3)

R _A	Ambient convection	R ₇	Plastic under steel edge
R ₁	Plastic	R ₈	Steel left
R ₂	Steel surface	R ₉	EPS Insulation
R ₃	Plastic right side small edge	R ₁₀	Plastic right side
R ₄	Plastic left side small edge	R ₁₁	EPS inside
R ₅	Plastic under steel edge	R ₁₂	Plastic surface
R ₆	Steel right side edge	R _B	RC Convection
		R ₁₃	Plastic sheet over the steel

Problem Implementation

A matlab code is devopled to determine the surface temperture for all the three cases. Flow chart discribing solution proceedure is shown in fig 12. Inputs to the code include ambient conditions, thermal conductivity, heat transfer coefficient and dimensions. Output of code includes surface temperature, total resistance of mullion and rate of heat transfer

```
function [SURFACE_TEMP,Rtotal,Q] = total (RA,R,RB, TA,TB)
%#codegen

RC= (R (5) +R (6) );
RD= (R (7) +R (8) );
RE= (R (10) *R (11) ) / (R (10) +R (11) );
RH= (RC*R (1) +R (4) *R (1) +RC*R (4) ) / (RC) ;

RG= (RC*R (1) +R (4) *R (1) +RC*R (4) ) / (R (1) );
RF= (RC*R (1) +R (4) *R (1) +RC*R (4) ) / (R (4) );
RI= (R (2) *RG) / (R (2) +RG) ;
RJ= (RF*R (9) ) / (RF+R (9) );

RK= (RJ*RD+RD*RI+RI*RJ) / (RJ) ;
RL= (RJ*RD+RD*RI+RI*RJ) / (RI) ;

RM= (RJ*RD+RD*RI+RI*RJ) / (RD) ;
RN= (R (3) *RL) / (R (3) +RL) ;

RO= (RE*RK) / (RE+RK) ;
RP=RN+RO;
RQ= (RH*RP*RM) / (RP*RM+RH*RM+RH*RP) ;
RR=RQ+R (12) ;
Rtotal= RA+RR+RB;
Q= (TA-TB) /Rtotal;
SURFACE_TEMP = -Q*RA+TA

end
```

Fig: 12 MATLAB Code for Surface Temperature Simulation results and discussion

Table 8. surface temperature in different cases

Cases	Surface temperature k	R total	Heat transfer Q (W)
Case 1	297.3	12.88	2.252
Case 2	299.8	19.23	1.508
Case 3 (0.25 mm)	299.8	19.26	1.506
Case 3 (0.5 mm)	299.9	19.29	1.503
Case 3 (1 mm)	299.9	19.36	1.496
Case 3 (2 mm)	299.9	19.49	1.488
Case 3 (3 mm)	299.9	19.62	1.478
Case 3 (5 mm)	300	19.87	1.459

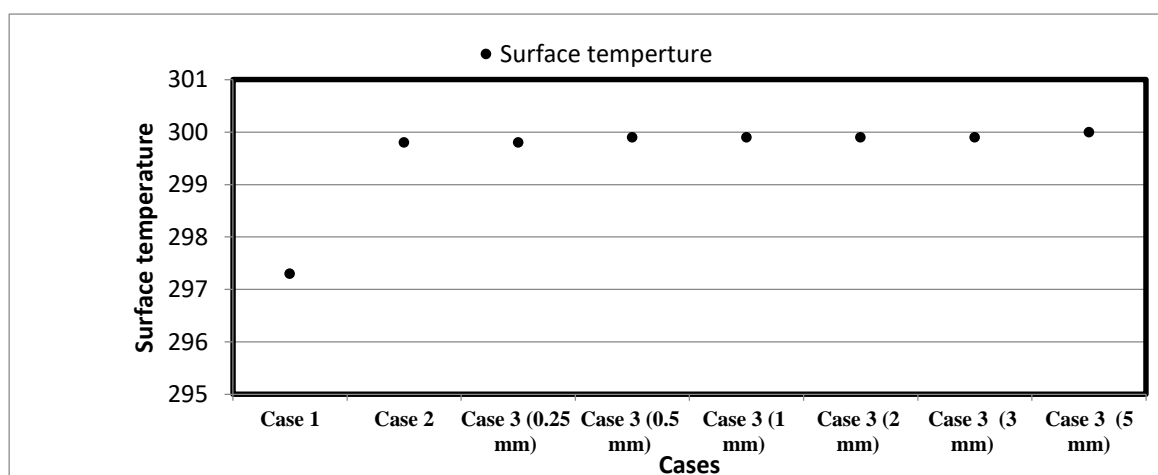

Fig: 13 surface temperature in different cases

Conclusion:

It is observed that surface temperature increases with the thickness of the sheet. But increasing thickness reduces the pull force of the gasket and the temperatures are found to be lower than the dew point temperature.

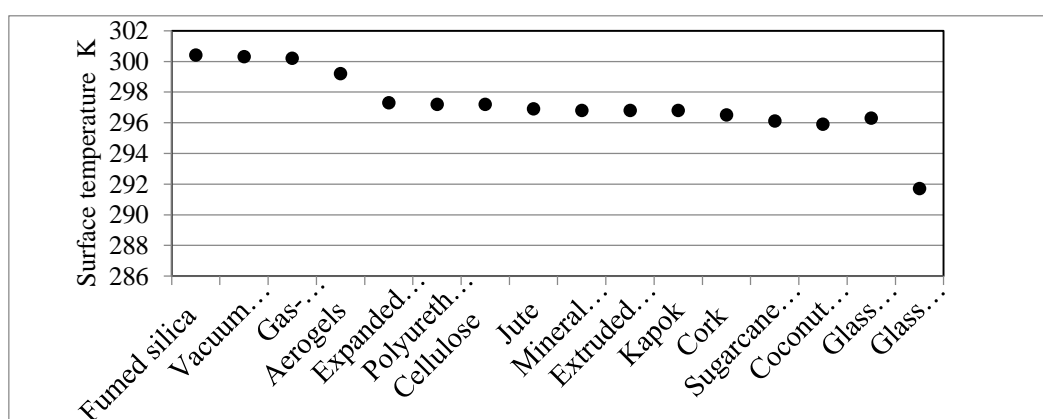

Fig: 14 Results of Simulation in terms of Surface Temperature in case 1

Observation from the above results:

1. If EPS is used, the surface temperature is found to be less than dew point temperature.
2. Even with better insulation materials like aerogel, VIP, silica, glass bubbles also results in temperature lower than dew point temperature 302 K. of mullion in case 1 by changing the plastics.

EXPERIMENTAL ESTIMATION OF SURFACE TEMPERATURE

Condensation test

The air gaps are present at the top and bottom of mullion. Six experiments are conducted with EPS insulation in three configurations with air gaps and closed air gaps. Temperatures along the vertical length of mullion are estimated by mounting thermocouples at respective locations. Similar six experiments are done with Rice husk as insulation material replacing EPS maintaining assumed ambient conditions in a chamber. 12 tests have been carried out in chamber and the results are presented in table 9.

Results of obtained Surface temperature on mullion

Table 9. Experimental Results of condensation test

S/No	Part	Insulation material	Top and bottom gaps (open /closed)	Temperature		
				Top	Mid	Bottom
1	Existing	EPS	Open	26.57	25.14	23.91
2	Plastic	EPS	Open	26.41	26.41	13.82
3	Strip	EPS	Open	22.15	24.18	9.39
4	Existing	EPS	Closed	26.57	24.58	20.91
5	Plastic	EPS	Closed	25.63	22.13	13.55
6	Strip	EPS	Closed	20.62	22.09	13.5
7	Existing	Rice husk	Open	21.29	17.23	21.24
8	Plastic	Rice husk	Open	20.89	19.72	12.22
9	Strip	Rice husk	Open	21.28	16.22	10.49
10	Existing	Rice husk	Closed	22.25	17.08	20.49
11	Plastic	Rice husk	Closed	20.79	20.74	14.34
12	Strip	Rice husk	Closed	21.29	16.42	14.04

Maximum surface temperature to avoid condensation is 302.85 K, which is the dew point temperature at an ambient temperature of 305 K and 80% relative humidity. From the numerical investigation, it is found that external surface temperature of flipper mullion is 297 K (Case 1).Surface temperature obtained after modifying the design and insulation material as described in Case 2 is found to be 299.56 K.

CONCLUSION

1. Maximum surface temperature to avoid condensation is 302.85 K, which is the dew point temperature at an ambient temperature of 305 K and 80% relative humidity. From the numerical investigation, it is found that external surface temperature of flipper mullion is 297 K (Case 1).
2. Surface temperature obtained after modifying the design and insulation material as described in Case 2 is found to be 299.56 K.
3. Core thermal conductivity makes highest effect, external surface temperature is found to be higher than the dew point temperature when Aerogel is used as insulation.
4. Rice husk with proper processing in terms of particle diameter and density can be a viable alternative.

Scope for future work

1. In the current design, air gaps are present at the top and bottom edges which significantly affect the outer surface temperature and they can be closed using plastic flap.
2. Analysis can be done after including the plastic flaps to study their affect on outer surface temperature.
3. Further analysis can be done by increasing the flipper mullion thickness to check whether the outer surface temperature is above dew point temperature.

ACKNOWLEDGEMENTS

I write this acknowledgement with great honor, pride and pleasure to pay my respects to all who enabled me either directly or indirectly in reaching this stage.

REFERENCES

1. Allena.M.S et al. "Advance microsphere insulation" Cryogenic Engineering Conference, 2003
2. Bello.S.R and Adegbulugbe, Comparative Study on Utilization of Charcoal, Sawdust and Rice Husk in Biomass Furnace-Dryer, Agricultural Engineering International: the CIGR Journal of Scientific Research and Development. Manuscript 1592, Volume XII, March, 2010.
3. Boreyko.J.B and Chen. C.H, "Self-Propelled Dropwise Condensate on Super hydrophobic Surfaces", The American Physical Society 2009.
4. Butler.J.C, "Flapper mechanism for refrigerator", US0273264A1, Nov 5, 2009.
5. Chekal.R.J,"Refrigerator incorporating French door with rotating mullion bar", Maytag Corporation, US7008032B2, Mar.2007
6. Creager.B. N, "Flexible mullion", 3210808, Oct .12, 19657, 2006.
7. Davis.M.W, Brown.S.G, "Refrigerator door mullion apparatus and system", US0073321A1, March. 29, 2012.
8. Fesmire.J.E,Sass.J, "Aerogel insulation application for liquid hydrogen launch vehicle tanks" space cryogenics workshop,
9. Gupta.C.P, Engineering Heat Transfer, University of Rookie, Nemchand and bros., 1997
10. Jeong.G.J, Han.J.M, "Refrigerator mullion with protective unit", US8167389B2, Samsung Electronics co., Ltd , May. 1 ,2012.
11. Kalnas.S.E, Jelle.B.P, "Vacuum insulation panel products", Applied Energy 116. 2014 355–375
12. Miersen.R.C, Gose.T.E, "Spring loaded mullion for French door refrigerator", US20140217877A1, Aug 2014.
13. Pandey.S, "Dropwise and film wise condensation", International Journal of Scientific & Engineering Research Volume 3, Issue 4, April-2012untsville, July 2007.
14. Psychometrics from ASHRAE Fundaments hand books, 2001.
15. Tekin.H.F, "A Theory of drop wise condensation" thesis submitted to Middle east technical university, 2005.
16. Wiley-VCH Verlag GmbH & Co. KGaA , Material Properties of Plastics, Laser Welding of Plastics ,2011