

Screening and Characterization of Polyhydroxybutyrate Producing *Bacillus flexus*

Arjun Reddy*, Kavitha P. Rao

*M.Tech Student, Department of Aeronautical Engineering, Institute of Aeronautical Engineering, Hyderabad, India

Assistant Professor, Department of Mechanical Engineering, Institute of Aeronautical Engineering, Hyderabad, India

ABSTRACT

Dwindling crude oil reservoirs and increasing environmental and societal concerns over harmful effects of synthetic plastics have increased the pressure on development of sustainable and environmentally friendly biopolymers like Polyhydroxybutyrate (PHB). Present work aimed at isolating and characterizing PHB producing bacteria from soil. Isolation from rhizospheric soil samples yielded 85 isolates, which were screened for PHB production by Sudan Black B followed by Nile Blue A staining procedures. Overall, 21.18% isolates tested positive for PHB production. The polymer production by the isolates was found to vary from 0.011- 0.186 g/L of the dry cell weight. The highest PHB yield was observed in R8, which was characterized for its morphological and biochemical properties. Based on its 16S rRNA gene sequences, isolate was identified as *Bacillus flexus*. The ability of the organism to produce protease, amylase and lipase indicated possibility of using various low cost agro-industrial, food and dairy wastes as carbon substrates for cost-effective PHB production. Its hydrolytic potential coupled with resistance to heavy metals and antibiotics can be explored for PHB production using waste water.

KEYWORDS: Biopolymer, Polyhydroxybutyrate, *Bacillus flexus*.

INTRODUCTION

Conventional petrochemical plastics have become an essential part of contemporary life because of their desirable qualities such as strength, lightness, durability and low production costs. However, they are recalcitrant to microbial degradation and remain persistent in the environment for a long time, thus accumulating at a rapid rate of approximately 25 million tons per year (Lathwal et al., 2015). They affect the aesthetic quality of cities, water bodies and natural areas. Improper methods of disposal such as burying or burning of plastic materials release harmful or toxic pollutants into the environment thereby endangering the biosphere. The recycled plastics have limited usage as their structure gets altered. The development and use of biodegradable plastics is therefore gaining more serious attention owing to increasing public concern over global environmental pollution and solid waste management of plastic materials (Snoei, 2015).

Polyhydroxyalkanoate (PHA) is one such biodegradable microbial polymer which is accumulated in bacteria as intracellular storage lipid granules. PHAs are synthesized by cells under growth-limiting conditions, when the carbon source is in excess and nitrogen, phosphorus, magnesium, or sulfur is present in a limiting concentration (Shi et al., 2007). There are more than 300 of such species known to produce PHBs such as *Azotobacter*, *Bacillus*, *Pseudomonas*, *Aeromonas sp.*, *Rhodopseudomonas sp.*, *Halomonas sp.*, *Methylobacteria*, transgenic *Escherichia coli* etc. (Berlanga et al. 2006). PHAs extracted from bacterial cells have properties similar to conventional plastics, such as polypropylene. Therefore, they are very good substitute of petrochemical thermoplastics. Several PHAs, in particular the homopolymer poly(3-hydroxybutyrate), P(3HB), and the copolymer poly(3-hydroxybutyrate-co-3-hydroxyvalerate), P(3HB-co-3HV), are considered for several applications in the packaging industry, medicine, pharmacy, agriculture and food industry, or as raw materials for the synthesis of enantiomerically pure chemicals etc. (Rehm and Steinbüchel, 2002).

However, despite numerous advantages and demand of biodegradable plastics, the commercialization of PHB has been met with limited success. The high cost of polymer production, together with high recovery cost, low yield and the lack of high-end market are the major bottlenecks in the commercialization of biodegradable plastics. The PHA content and its composition are influenced mainly by the strain of the microorganism, the type of substrate employed and its concentration, and other growth conditions. To achieve a cost effective PHA production, the availability of an efficient bacterial strain is a prerequisite (Valappil et al., 2007).

The present work was initiated to screen, isolate, identify and characterize potent PHB producing bacterial isolate from soil.

MATERIALS AND METHODS

Sample collection

Rhizosphere soil samples, randomly collected from 3.0 to 4.0 cm below the surface were collected in sterile glass bottles transported on ice to the laboratory and processed within two h of their collection. Isolation of bacteria was performed by serial dilution technique, after crushing the soil to uniform size. Aliquots of serially diluted soil samples were surface spread onto nutrient agar, minimal medium and Ashby's Mannitol Agar. The plates were incubated at $29 \pm 1^\circ\text{C}$ for 24 – 72 h. Various colonies of different morphologies including branched and rhizoidal forms were individually picked and sub cultured 3-4 times on nutrient agar plates for purification. Well isolated, morphologically distinct colonies were stored at 4°C by streaking on to nutrient agar slants till further use (Aarathi and Ramana, 2011).

Primary screening for PHB production

All the isolates were qualitatively tested for PHB production using Sudan Black B dye. Pure 18 h old isolates were spot inoculated on PHA detection agar (PDA) [(g/L: Glucose 20, $(\text{NH}_4)_2\text{SO}_4$ 0.2, KH_2PO_4 13.3, MgSO_4 1.3, Citric Acid 1.7, Trace element solution 10 mL, [(g/L): $\text{FeSO}_4 \cdot 7\text{H}_2\text{O}$ 10, $\text{ZnSO}_4 \cdot 7\text{H}_2\text{O}$ 2.25, $\text{CuSO}_4 \cdot 5\text{H}_2\text{O}$ 1, $\text{MnSO}_4 \cdot 5\text{H}_2\text{O}$ 0.5, $\text{CaCl}_2 \cdot 2\text{H}_2\text{O}$ 2.0, $\text{Na}_2\text{B}_4\text{O}_7 \cdot 10\text{H}_2\text{O}$ 0.23, $(\text{NH}_4)_6\text{Mo}_7\text{O}_{24}$ 0.1, 35% HCl 10 mL]; Agar, 20.0, pH 6.8 - 7.0) (Naheed *et al.*, 2011) and incubated at $29 \pm 1^\circ\text{C}$ for 48 h. Ethanolic solution of Sudan Black B (0.05%) was poured over the colonies and the plates were kept undisturbed for 30 min. They were then washed with ethanol (98 %) to remove the excess stain from the colonies. The dark blue coloured colonies were taken as positive for PHB production (Phanse *et al.*, 2011).

Secondary screening for PHB production

Sudan black B positive isolates were checked for PHA production by a more specific stain, Nile blue A. This staining method is a more rapid and sensitive, viable colony method allowing discrimination between PHA-negative and PHA-positive strains. This dye was incorporated in PHA detection agar containing 2% glucose at a concentration of $0.5 \mu\text{g}/\text{mL}$ and growth of the 18 h old isolates was monitored for 24 -48 h. The isolates which showed bright orange fluorescence on irradiation with UV light (distance of about 10 cm) were selected as PHA accumulators (Bhuwal *et al.*, 2013).

Quantitative analysis of PHB produced by the isolates

Putative PHB producers screened on the basis of staining procedures were subjected to production and quantification of the PHB under monophasic cultivation. PHB production was studied in 250mL Erlenmeyer flask containing 50mL of sterile mineral medium [(g/L of D/W): Glucose 20.0, $\text{Na}_2\text{HPO}_4 \cdot 12\text{H}_2\text{O}$ 4.8; KH_2PO_4 2.65; $(\text{NH}_4)_2\text{SO}_4$ 4; $\text{MgSO}_4 \cdot 7\text{H}_2\text{O}$ 0.3; $\text{FeSO}_4 \cdot 7\text{H}_2\text{O}$ 0.01; $\text{CaCl}_2 \cdot 2\text{H}_2\text{O}$ 0.01 and 1mL trace element solution (g/L of D/W): H_3BO_3 0.3; $\text{CoCl}_2 \cdot 6\text{H}_2\text{O}$ 0.2; $\text{ZnSO}_4 \cdot 7\text{H}_2\text{O}$ 0.03; $\text{MnCl}_2 \cdot 4\text{H}_2\text{O}$ 0.03; $\text{NaMoO}_4 \cdot 2\text{H}_2\text{O}$ 0.03; $\text{NiCl}_2 \cdot 6\text{H}_2\text{O}$ 0.02 and $\text{CuSO}_4 \cdot 5\text{H}_2\text{O}$ 0.01, pH 7.0] as production medium. They were inoculated with 1.0% (v/v) inoculum of 18h old culture grown on nutrient agar at $29 \pm 1^\circ\text{C}$. After 72h of incubation on rotating orbital shaker (Labtop Quality Lab Equipment, India) at 150 rpm at $29 \pm 1^\circ\text{C}$ for 72 h, culture broth was centrifuged for 15 min at 6000 rpm. The total cell dry weight (CDW g/L) was determined after drying the biomass to a constant weight at 60°C for 24 h. The dried cells were held in 5 volumes of chloroform and left overnight at room temperature. Clear chloroform layer was obtained by filtering with Whatman filter paper No. 1. PHB crystals were obtained after evaporation of chloroform and used for gravimetric estimation of PHB (Lakshman, 2004).

Percentage of PHA calculated from the cell dry weight (CDW) was as follows:

$$\text{Percentage of PHB} = \frac{\text{Dry weight of extracted PHB}}{\text{CDW (g/L)}} * 100 \quad (1)$$

The isolate producing maximum quantity of PHB was chosen for further work.

Molecular identification of isolate

The selected isolate was initially examined for its morphological, cultural and standard biochemical tests according to Bergey's Manual of Systematic Bacteriology (Sneath *et al.*, 1986) followed by molecular identification of the isolate. Genomic DNA of the isolate extracted from 5 mL overnight culture by using Chromous bacterial genomic DNA isolation kit was checked on agarose gel for purity and quantity. Approximately 1.5kb of 16SrRNA was amplified by polymerase chain reaction. Primers used were: Forward primer: 5'- AGAGTTTGATCMTGGCTCAG-3' and Reverse primer: 5'- TACGGYTACCTTGTTACGACTT - 3'. The PCR mixture consisted of 400 ng of each primer, 1 μL of chromosomal DNA, 4 μL dNTPs (2.5mM each) and 1 μL of Taq polymerase (3U/ μL) with 101 μL of polymerase buffer (10X) containing MgCl_2 . The PCR reaction was carried out for 35 cycles of 94°C for 30 sec, 55°C for 30 sec and then 72°C for 1 min. The PCR product was analyzed on 1.0% agarose gel containing 0.5 $\mu\text{g}/\text{mL}$ ethidium bromide and visualized under UV. Electrophoresis was carried out for 20 min at 150 V. PCR products obtained were Gel eluted using Chromous Gel extraction kit. The amplified 16S rDNA gene PCR products from the isolate, after precipitation using

isopropanol were directly sequenced with forward and reverse primers on the ABI 3500 XL Genetic Analyzer. Forward and reverse sequences were assembled and contig was generated after trimming the low quality bases. The 16S rRNA sequences were compared with all accessible sequences in databases using the BLAST (BLASTN 2.2.30+) server at NCBI (National Centre for Biotechnology Information <http://www.ncbi.nlm.nih.gov>). Based on maximum identity score first few sequences were selected and aligned using multiple sequence alignment software ClustalW2. The phylogenetic tree was constructed from evolutionary distances using the neighbor-joining method.

Study of hydrolytic enzyme activities

The isolate was evaluated for its ability to produce hydrolytic enzymes such as protease, amylase and lipase in order to explore its ability to use waste materials as sole source of carbon. Mineral salts medium agar plates containing 1% w/v of skimmed milk, starch and olive oil as the sole sources of carbon for detecting protease, amylase and lipase activity respectively. Enzyme activity was detected by spot inoculating 18 h old isolate on respective plates incubated at $29 \pm 1^\circ\text{C}$ for 24h for detection of amylase and protease activity; and at 37°C for 7 days for detection of lipase activity. A clear zone of hydrolysis observed around the colony of the inoculated bacteria was taken as an indication of production of exoenzymes (Israni and Srividya, 2013).

Detection of heavy metal resistance by the isolate

Minimum inhibitory concentration (MIC) for heavy metals like mercury (HgCl_2), chromium ($\text{K}_2\text{Cr}_2\text{O}_7$), lead ($\text{PbSO}_4 \cdot 2\text{H}_2\text{O}$) and copper (CuCl_2) was determined for the selected isolate. Nutrient agar plates supplemented with different concentrations of the metal salts i.e., mercuric chloride, potassium dichromate, lead sulfate, copper chloride added individually (25, 50, 100, 150, 200, 250 and 500 $\mu\text{g}/\text{mL}$) were prepared. Plates were inoculated aseptically by the exponentially growing cultures of the selected bacterial isolate. Minimum inhibitory concentration was taken as that highest concentration of the metal supporting the growth of the isolates after incubation at room temperature ($29 \pm 1^\circ\text{C}$) for 48 h (Fleck *et al.*, 2000).

Detection of antibiotic resistance by the isolate

Antibiotic Sensitivity Testing (AST) of the isolates was performed by using standard Kirby Bauer disc diffusion method on Mueller Hinton agar by using commercially available antibiotic hexadiscs of Ampicillin (25 μg), Norfloxacin (10 μg), Co-Trimoxazole (25 μg), Cephalothin (30 μg), Nitrofurantoin (300 μg) and Nalidixic acid (30 μg) (Hi Media Laboratories, Mumbai). Individual 18 h old isolates grown in nutrient broth were inoculated in 5mL nutrient broth and grown for further 2-3 h at $29 \pm 1^\circ\text{C}$. These isolates were swabbed on Mueller Hinton agar plates and hexadiscs were placed. Incubation of plates was done at $29 \pm 1^\circ\text{C}$ for 24 h. Zones of inhibition were measured and resistance pattern was evaluated (Bauer *et al.*, 1966).

RESULTS AND DISCUSSION

The rhizosphere soil layer, associated with a large number of plants is influenced by biotic and abiotic factors as a result of natural and anthropogenic activities. Indigenous microorganisms in the rhizosphere are adapted to temporal and spatial variations in nutrient availability and changing conditions of the soil environment. Fluctuating nutrient contents in the composition of the root exudates lead to, either a kind of nutrient stress or a carbon excess in the rhizospheric soil. This supports microbial populations actively involved in PHA accumulation to meet the metabolic energy requirements during starvation period (Israni and Srividya, 2013). Bacteria capable of inclusion of storage substances have a competitive advantage over other bacteria. Thus, rhizosphere appears to be a good source for the isolation of PHB producers (Lathwal *et al.*, 2015). In the present work, 85 bacterial isolates of varying colony morphologies including rhizoidal and branched colonies typical for *Bacillus* sp. were obtained from 15 different rhizospheric soil samples.

Initial screening of the isolates was based on dark blue colouration of the colonies after Sudan Black B staining. The Sudan group of dyes has long been used as a histochemical test of the presence of lipids in cells. The dye is more soluble in the lipid material than in the stain solution and therefore it moves into the lipid (Bartholomew, 1981). Sudan Black, in particular, has been utilized as a presumptive test for the presence of PHB even though it stains all lipophilic storage materials (Serafim *et al.*, 2002). Forty two of the 85 isolates tested positive with Sudan Black B.

These isolates were further subjected to secondary screening using Nile blue A staining. The Nile Blue A technique allows for fast screening and more specific as well as sensitive visualization of PHA granules. Nile Blue does not stain either glycogen or poly-P granules but it does stain lipophilic storage materials other than PHA, such as waxes and fats (Ostle and Holt, 1982; Paladino, 2009). Nile blue A is a basic oxazine dye which is soluble in water and ethyl alcohol. The oxazone form of the dye, known as either Nile Pink or Nile Red, is formed spontaneously in aqueous solution and is responsible for the bright fluorescence of stained PHA granules. Nile pink diffuses through the cytoplasmic membranes of bacterial cells and binds specifically to PHA granules which

fluoresce with orange color under excitation wavelength of 360/460 nm (Sindhu et al., 2011; Tripathi et al., 2013). The fluorescent response of Nile Blue increases with increasing PHA concentration and therefore can be used to evaluate the variation in PHA storage. Because the emitted light is of high intensity it is often possible to distinguish PHA containing biomass at low magnification (Serafim et al., 2002). Overall, out of the total of 85 isolates, 18 isolates (21.18%) appeared to be PHB producers showing fluorescence of varying degree. Wu et al. (2000) reported that over 30% of soil-inhabiting bacteria produce polyhydroxyalkanoates (PHAs).

The putative PHB producing isolates obtained after secondary screening were subjected to tertiary screening in shake flask production. The PHB content varied between 0.011- 0.186 g/L (Table 1). Isolate R 8 produced 0.186 g/L PHB and hence was chosen for further study. Batch fermentation for PHB production is a popular process due to its flexibility and low operation costs. However, it is associated with low PHB productivity since after utilization of the carbon source; bacterial cells degrade the accumulated PHB resulting in reduced PHB content as was seen in this study (Zinn *et al.*, 2001). The model of two-stage fermentation operation where cell growth phase is separated from production phase can improve the performance of PHB synthesis and may improve the yields further (Chen et al., 2013).

Table 1: Comparison of PHB production by isolates

Isolates	Dry weight (g/L)	PHB weight (g/L)	% PHB
RS 1	0.117±0.026	0.024±0.0005	20.17
RS 2	0.234±0.005	0.018±0.0004	7.71
RS 4	0.277±0.006	0.012±0.0003	4.33
RS 5	0.636±0.014	0.016±0.0003	2.44
RR 1	0.189±0.004	0.016±0.0004	8.73
RR 4	0.177±0.004	0.056±0.0013	31.73
RR 5	0.533±0.012	0.007±0.0002	1.31
RR 8	1.457±0.033	0.186±0.0042	12.81
RA 1	0.732±0.016	0.018±0.0004	2.39
RV 1	2.010±0.045	0.011±0.0001	0.55
RV 2	1.314±0.030	0.017±0.0004	1.27
RV 3	1.166±0.026	0.020±0.0004	1.67
RC 3	1.182±0.027	0.015±0.0003	1.27
RC 7	0.480±0.011	0.040±0.0009	8.33
RG 1	2.850±0.064	0.057±0.0013	2.00
RG 3	0.247±0.006	0.024±0.0005	9.87
RG 4	2.258±0.051	0.064±0.0014	2.84
RG 6	0.978±0.022	0.067±0.0015	6.85

The isolate was identified using a series of biochemical tests and morphological characteristics. Microscopically the colonies appeared as Gram positive motile rod shaped bacteria with round ends and oval, centrally placed ellipsoidal endospores in un-swollen sporangia. Morphologically these isolates appeared as circular, off white, flat, smooth and opaque colonies. Sporulation occurred after 72 hours of growth. It produced acid from glucose, fructose, maltose, galactose, raffinose, trehalose, mellibiose, lactose and sucrose.

The 16SrRNA gene sequence analysis has been widely used for the identification of the species. The sequence of 16SrRNA provides a measure of genomic similarity about the level of species allowing comparison of relatedness across the genus, family etc. Analysis of the 16SrRNA gene sequences of isolate R 8 was performed using NCBI-BLAST (National centre for Biotechnology Information <http://www.ncbi.nlm.nih.gov>). Based on maximum identity score, few sequences were selected and aligned using multiple sequence alignment software ClustalW2. The sequence similarity within the species was 99-100%. A phylogenetic tree demonstrated that the isolate was a member of *Bacillus flexus* species. Sequence similarity calculations after neighbor joining analysis showed strong homology with other *Bacillus flexus* strains available in the database. *Bacillus flexus* is a novel Gram-positive, strictly aerobic, facultative alkaliphilic bacterium. These microbial species have the ability to synthesize active

enzymes under extreme pH conditions (Anupama et al., 2014). Divyashree (2008) isolated PHB producing *Bacillus flexus* from municipal waste disposal yard.

Figure 1: Phylogenetic relationship between isolate R8 and other selected *Bacillus flexus* strains available in the database

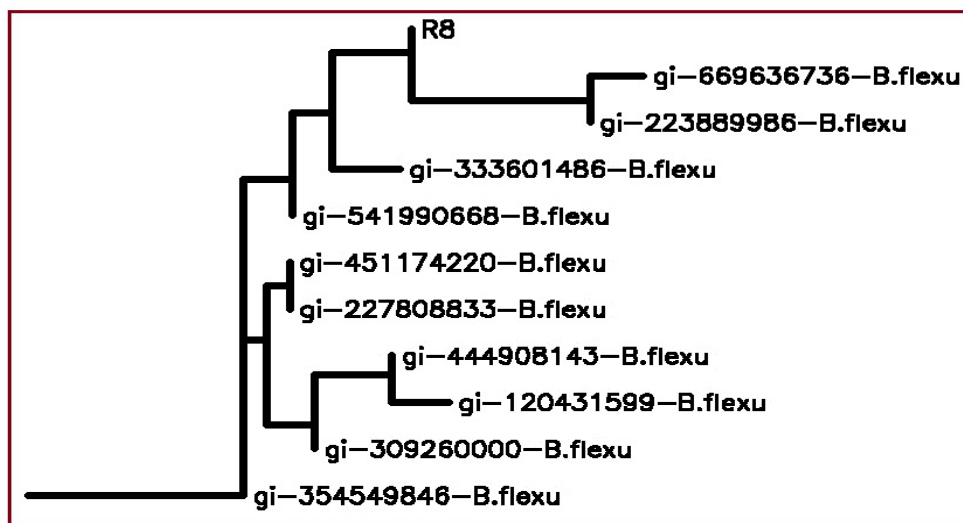

Currently, PHAs are produced on the industrial scale exclusively using Gram-negative bacteria (such as *Cupriavidus necator*, *Methylobacterium organophilum*, *Pseudomonas oleovorans* and recombinant *Escherichia coli*). Gram-negative bacteria have thinner cell walls and would be easier to get the PHAs extracted from, as well as produce higher PHA yields. However, pyrogenic outer membrane lipopolysaccharide (LPS) endotoxins copurify with PHAs produced. The presence of LPS induces a strong immunogenic reaction and is therefore undesirable for the biomedical application of the PHAs (Valappil et al., 2007). Gram-positive bacteria lack LPS and are hence are better sources of PHAs for use in biomedical applications (Valappil et al., 2007; Berekaa and Al Thawadi, 2012; Gowda and Shivakumar, 2013).

It has been reported in the literature that Gram-positive bacteria have as much as 50% of the cell's dry weight composed of peptidoglycan and 40% of weight by PHB (Colwell and Grigorova., 1987). The reason for choosing a Gram-positive bacterium in contrast to a Gram-negative bacterium is partially due to the potential ability to combine the Gram-positive cells' abundant amount of peptidoglycan with the modest amount of PHB (as compared to Gram-negatives' 70-80% PHB). This combination can lead to new ideas not previously pursued. PHB, often very weak and fragile and peptidoglycan, often not very strong once extracted from the bacterial cell, if recombined perhaps could create an ideal co-polymer that would be stronger than either PHB or peptidoglycan by itself. Gram-positive bacteria may thus be favored because of their ability to produce large amounts of peptidoglycan which can aid as a co-polymer (Paladino, 2009).

Amongst Gram positive organisms, *Bacillus* sp. was identified as one of the first Gram-positive bacteria capable of PHA production. *Bacillus* is genetically and biochemically well-defined and offers several advantages, such as, short generation time, attractive host for gene expression, easy growth to very high cell density, ability to tolerate high temperatures and high osmotic pressures, ability to synthesize different types of polyesters composed of various kinds of monomers depending on the fermentation conditions and the carbon source supplied etc. (Wu et al., 2001; Valappil et al., 2007; Nagamani and Mahmood, 2013). *Bacillus* is one of the most versatile PHA producers with great biodegradation potential. Its chemo organotropic features and inherent ability to produce various hydrolytic enzymes have been explored for PHA production using a variety of inexpensive substrates such as various agricultural raw materials as a carbon source (Omar et al., 2001).

Many studies involve the use of *Bacillus* sp. for the production of PHA such as *B. thuringiensis* (Rohini et al., 2006), *B. cereus* (Valappil et al., 2007), *B. subtilis* (Singh et al., 2009). Israni and Srividya (2013) reported PHB production ranging from 0.004 -0.806 g/L by various *Bacillus* sp. isolated from rhizospheric soil. Rajendran et al., (2013) reported PHB production of 0.171 g/L by *Bacillus* sp. after 72 h of cultivation in minimal medium containing glucose. Prabha et al. (2015) achieved PHB production of 0.102 g/L by *Bacillus* sp. in minimal medium containing sucrose after 48 h.

PHB production strategies have not yet been able to pass the test of economic feasibility due to the high current production costs. The cost of the raw materials has been shown to contribute 50% of the entire production costs. Cost-efficient PHB production based on such wastes will help not only in reducing the production costs but also in alleviating disposal problems (Pal et al., 2009; Israni and Srividya, 2013). The carbon-source-utilization spectrum is an important element in choosing a particular bacterial strain for a biotechnological process (Gomez et al., 1996). *Bacillus flexus* showed its ability to produce various hydrolytic enzymes – protease, amylase and lipase indicating the potential of transforming complex substrates to simple absorbable metabolites and making them available for PHB production. The amylase and protease-producing ability of *Bacillus flexus* makes it attractive for cost effective PHB production from alternative carbon sources, like agro-wastes and food wastes rich in starch and protein. Fatty acids derived from agricultural triacylglycerols (i.e., vegetable oils, animal fats, and coproducts derived thereof such as recycled grease) have now attracted the attention of researchers because they may serve as a better fermentative substrate in certain instances for microbial growth and production of PHB (Solaiman et al., 2006). Fatty acids are desirable feedstock for PHAs production because they are relatively cheap compared to most sugars (Snoei et al., 2015). The lipase production by the isolate indicates its ability to utilize these substrates.

In order to further increase the potential range of substrates such as use of domestic waste water for PHB production, *Bacillus flexus* was evaluated for its resistance to heavy metals as well as antibiotics. The isolate was resistant to Cephalothin and Ampicillin amongst the tested antibiotics and could tolerate upto 50µg/mL of chromium, 200 µg/mL of mercury, 100 µg/mL of lead and 100 µg/mL of zinc. Domestic wastewater is mainly regarded as organic pollutant due to its high biological oxygen demand (BOD) and organic and inorganic constituents like carbohydrates, lignin, fats, soaps, synthetic detergents, proteins and their decomposition products, oxygen demanding substances, soluble inorganic material (ammonia, road-salt, sea-salt, cyanide, hydrogen sulfide, thiocyanates, thiosulfates, etc.), toxic chemical compounds (heavy metals, pesticides, herbicides, arsenic, cadmium, chromium, copper, lead, mercury, zinc, etc.) (Ceyhan and Ozdemir, 2011). Several PHA-producing microbes could simultaneously degrade pollutants and synthesize PHAs, since the metabolism of PHA synthesis could be expressed in hostile environments (Chen et al., 2013). *Bacillus flexus* with its innate hydrolytic potential, tolerance to heavy metals and resistance to antibiotics could be further explored for cost effective production of PHAs using low cost agro-industrial, food and dairy wastes.

CONCLUSION

Petrochemical-derived plastic materials are one of the biggest pollutants of the environment because not only do they persist in the environment, but they are also disposed of in large volumes. The potential to circumvent these problems lies in exploiting bacterial metabolic activities especially those related to generation of new environmentally friendly and sustainable plastics. Degradable polymers have found applications in a lot of areas, e.g., in medicine such as in sutures, wound dressings, surgical implants, and controlled-release drug delivery systems. Besides that, there is a great demand for degradable plastics for use as garbage bags, food and beverage containers, and for mulching. This can be achieved by identifying new organisms having wide range of substrates and high growth rates. In the present work, amongst the 85 isolates, 21.18% seemed to be potential PHB producers. PHB production carried out using monophasic cultivation produced from 0.011- 0.186 g/L of PHB. The isolate producing maximum PHB, R8 was identified as *Bacillus flexus* using biochemical and molecular techniques. The organism showed hydrolytic enzyme activities along with resistance to heavy metals and antibiotics, which can be used to widen its substrate range for cost effective PHB production.

ACKNOWLEDGMENTS

The study was supported by a research grant from University Grants Commission, WRO to the second author. The authors gratefully acknowledge the financial support.

REFERENCES

- [1] Aarathi, N. and Ramana, K. (2011). Identification and characterization of polyhydroxybutyrate producing *Bacillus cereus* and *Bacillus mycoides* strains. *International Journal of Environmental Sciences*, 1 (5), 744–756.
- [2] Anupama R., Makari HK., Hosmani Shankar P. (2014). Isolation of 16S rRNA and Phylogenetic Analysis of *Bacillus Flexus* Colonizing in Berry of *Coffea Arabica*. *Research & Reviews: Journal of Computational Biology*, 3(1), 6-14.
- [3] Bartholomew J. W. (1981). Stains for microorganism in smear. In: Clark G. (ed) *Staining procedures*. (pp. 375-440) 4 th Ed. Baltimore: Williams and Wilkins.
- [4] Bauer, A. W., Kirby W. M., J. C. Sherris J. C., and Turk M. (1966). Antibiotic susceptibility testing by a standardized single disc method. *American Journal of Clinical Pathology*, 45, 493-496.

- [5] Berekaa, M. M., Al Thawadi, A. M. (2012). Biosynthesis of polyhydroxybutyrate (PHB) biopolymer by *Bacillus megaterium* SW1-2: Application of Box-Behnken design for optimization of process parameters. *African Journal of Microbiology Research*, 6(4), 838-845.
- [6] Berlanga, M., Montero, M. T., Hernández-Borrell, J., Guerrero, R. (2006). Rapid spectrofluorometric screening of poly-hydroxyalkanoate- producing bacteria from microbial mats. *International Microbiology*, 9, 95-102.
- [7] Bhuwal, A. K., Singh, G., Aggarwal, N. K., Goyal, V., and Yadav, A. (2013). Isolation and Screening of Polyhydroxyalkanoates Producing Bacteria from Pulp, Paper, and Cardboard Industry Wastes. *International Journal of Biomaterials*, 1, 9 <http://dx.doi.org/10.1155/2013/752821>.
- [8] Ceyhan, N. and Ozdemir, G. (2011). Poly- β -hydroxybutyrate (PHB) production from domestic wastewater using *Enterobacter aerogenes*. *African Journal of Microbiology Research*, 5(6), 690–702.
- [9] Chen G. Q., Zhang G., Park S. J., Lee S. (2001). Industrial production of poly(hydroxybutyrate-co-hydroxyhexanoate). *Applied Microbiology and Biotechnology*, 57, 50-55.
- [10] Chen, B-Y., Hung, J-Y., Shiau, T-J., Wei, Y-H. (2013). Exploring two-stage fermentation strategy of polyhydroxyalkanoate production using *Aeromonas hydrophila*. *Biochemical Engineering Journal*, 78, 80– 84.
- [11] Colwell, R. R. and Grigorova R. (1987). Current methods for classification and identification of microorganisms. (pp. 405-458) London, Academic Press.
- [12] Divyashree M. S. (2008) *Polyhydroxyalkanoate from Bacillus sp.: its production, isolation and characterization*. Ph. D., University of Mysore.
- [13] Gomez J. G. C. , Rodrigues M. F. A. , Alli R. C. P. , Torres B. B. , Bueno Netto C. L., Oliveira M. S. and da Silva L. F. (1996). Evaluation of soil gram-negative bacteria yielding polyhydroxyalkanoic acids from carbohydrates and propionic acid. *Applied Microbiology and Biotechnology*, 45, 785–791.
- [14] Gowda, V., and Srividya, S. (2013). Poly (3)hydroxybutyrate (PHB) production in *Bacillus thuringiensis* IAM 12077 under varied nutrient limiting conditions and molecular detection of class IV PHA synthase gene by PCR. *International Journal of Pharma and Bio Sciences*, (4), B794-802.
- [15] Israni N. and Shivakumar S. (2013). Combinatorial screening of hydrolytic enzyme/s and PHA producing *Bacillus* spp., for cost effective production of PHAs. *International Journal of Pharma and Bio Sciences*, 4(3), (B) 934 – 945.
- [16] Lakshman, K. (2004). *Studies on the production of biopolymers by Rhizobium sps. their isolation and characterization*. Ph. D., University of Mysore.
- [17] Lathwal, P., Nehra, K., Singh, M., Jamdagni, P., And Rana, J. S. (2015). Optimization of Culture Parameters for Maximum Polyhydroxybutyrate Production by Selected Bacterial Strains Isolated from Rhizospheric Soils. *Polish Journal of Microbiology*, 64 (3), 227–239.
- [18] Nagamani, P. and Mahmood, S. K. (2013). Production of poly (3-hydroxybutyrate-co-3-hydroxyvalerate) by a novel *Bacillus* OU40^T from inexpensive carbon sources. *International Journal of Pharma and Bio Sciences*, 4(1), (B) 182 – 193.
- [19] Naheed, N., Jamil, N. and Hasnain, S. (2011). Screening of contaminated soils for biodegradable plastic producing bacteria and profiling of their resistance markers. *African Journal of Microbiology Research*, 5(24), 4097-4104.
- [20] Omar S., Rayes A., Eqaab A., Viss I. and Steinbuechel A. (2001). Optimization of cell growth and poly(3-hydroxybutyrate) accumulation on date syrup by a *Bacillus megaterium* strain. *Biotechnology Letters*, 23, 1119–1123
- [21] Ostle, A. G. and J. G. Holt. (1982). Nile blue A as a fluorescent stain for poly-beta-hydroxybutyrate. *Applied and Environmental Microbiology*, 44, 238-241.
- [22] Pal, A., Prabhu, A., Arun Kumar A., Rajagopal, B., Dadhe, K., Ponnamma V. and Shivakumar, S. (2009). Mutagenesis of *Bacillus thuringiensis* IAM 12077 for increasing poly (- β -)hydroxybutyrate (PHB) production. *Turkish Journal of Biology*, 33, 225-230.
- [23] Paladino, L. (2009). Screening, Optimization and Extraction of Polyhydroxyalkanoates and Peptidoglycan from *Bacillus megaterium*. Thesis submitted to Michigan Technological University.
- [24] Phanse, N., Chincholikar, A., Patel, B., Rathore, P., Vyas, P. and Patel, M. (2011) Screening of PHA (polyhydroxyalkanoate) producing bacteria from diverse sources. *International Journal of Biosciences*, 1(6), 27-32.
- [25] Prabha, S, Sahi, S.K, Yadav, R. and Yadav, A. (2015). Isolation and optimization of culture conditions for Poly- β -Hydroxybutyrate (Biopolymer) producing bacteria. *Journal of Global Biosciences*, 4, 1926 – 1929
- [26] Rajendran, R., Mekala, M. and Suganya, K. (2013). PHB production by *Bacillus* species using the cheap substrate groundnut oil cake. *International Journal of Pharma and Bio Sciences*, 4(1), (B) 1006 – 1015.
- [27] Rehm, B. H. A., Steinbüchel, A. (2002). PHA Synthases: The Key Enzymes of PHA Synthesis. In: Steinbüchel A., Doi Y. (Eds.) *Biopolymers, Vol. 3a*, (pp. 173–215), Wiley-VCH, Weinheim, Germany.

- [28] Rohini, D., Phadnis, S. and Rawal, S.K. (2006). Synthesis and characterization of poly- β -hydroxybutyrate from *Bacillus thuringiensis* R1. *Indian Journal of Biotechnology*, 5, 276-283.
- [29] Serafim L. S., Lemos P. C., Levantesi C., Tandoi V., Santos H. and Reis MAM. (2002). Methods for detection and visualization of intracellular polymers stored by polyphosphate accumulating microorganisms. *Journal of Microbiological Methods*, 51, 1–18.
- [30] Shi H., Lee C. and Ma W. (2007). Influence of electron acceptor, carbon, nitrogen, and phosphorus on polyhydroxyalkanoate (PHA) production by *Brachymonas* sp. P12 *World Journal of Microbiology and Biotechnology*, 23, 625–632. DOI 10.1007/s11274-006-9271-9
- [31] Sindhu, R., Ammu, B., Binod, P., Deepthi, S. K., Ramachandran, K. B., Soccoland, C. R. and Pandey, A. (2011). Production and Characterization of Poly-3-hydroxybutyrate from Crude Glycerol by *Bacillus sphaericus* NII 0838 and Improving Its Thermal Properties by Blending with Other Polymers. *Brazilian Archives Of Biology And Technology*, 54(4), 783-794.
- [32] Singh M., Patel S.K.S. and Kalia V.C. (2009). *Bacillus subtilis* as potential producer for polyhydroxyalkanoates. *Microbial Cell Factories*, 8(1), 38 -40.
- [33] Sneath, P. H. A., Mair, N. S., Sharpe, M. E. & Holt, J. G. (editors) (1986). *Bergey's Manual of Systematic Bacteriology* (vol. 2.) Baltimore: Williams and Wilkins.
- [34] Snoei J., Luong D. and Jukka Seppala. (2015). Fatty acids as an alternative carbon source for mclpolyhydroxyalkanoate production by *Pseudomonas fluorescens* sc4. *International Journal of Latest Research in Science and Technology*, 4(1), 7-12.
- [35] Solaiman, D.K.Y., Ashby, R.D., Foglia, T. and Marmer, W.N. (2006). Conversion of Agricultural Feedstock and Coproducts into Poly(Hydroxyalkanoates). *Applied Microbiology and Biotechnology*, 71(6), 783-789.
- [36] Tripathi, A. D., Srivastava, S. K. and Singh, R. P. (2013). Statistical optimization of physical process variables for bio-plastic (PHB) production by *Alcaligenes* sp. *Biomass and Bioenergy*, 55, 243-250.
- [37] Valappil, S. P., Misra, S. K., Boccaccini, A. R., Keshavarz, T., Bucke, C. and Roy, I. (2007). Large-scale production and efficient recovery of PHB with desirable material properties, from the newly characterized *Bacillus cereus* SPV. *Journal of Biotechnology*, 132, 251–258.
- [38] Wu Q., Huang H., Hu G., Chen J., Ho KP. and Chen GQ. (2001). Production of poly-3-hydroxybutyrate by *Bacillus* sp. JMa5 cultivated in molasses media. *Antonie van Leeuwenhoek*, 80(2), 111-118.
- [39] Wu Q., Sun S.Q., Yu P.H.F., Chen A.X.Z. and Chen G.Q. (2000). Environmental dependence of microbial synthesis of polyhydroxyalkanoates. *Acta Polymerica Sinica*, 6, 751–756.
- [40] Zinn, M., Witholt, B. and Egli, T. (2001). Occurrence, synthesis and medical application of bacterial polyhydroxyalkanoate. *Advanced Drug Delivery Reviews*, 53, 5–21.