

**Finite Element Based Fatigue Assessment of AM60 Magnesium Alloy Wheel Hub for Aircraft Applications****M. Rajasekhar\*, K. Praveen Kumar, Dr. T. V. Rao**

\* Assistant Professor, Department of Mechanical Engineering, RVR &amp; JC College of Engineering, Guntur, Andhra Pradesh, India

Assistant Professor, Department of Mechanical Engineering, RVR &amp; JC College of Engineering, Guntur, Andhra Pradesh, India

Professor, Department of Mechanical Engineering, GITAM University, Visakhapatnam, Andhra Pradesh, India

**ABSTRACT**

The majority of service failures in aircraft components occur by fatigue. In the present paper, the fatigue analysis is carried on the aircraft wheel hub at radial load conditions on magnesium alloy in the finite element environment. The radial fatigue test conditions are applied to aircraft wheel in Finite element software and fatigue analysis is done. The fatigue life, von-Mises stress, deformation and safety factor of wheel hub are obtained for each load condition. The process is repeated at various fatigue load conditions on Mg alloy aircraft wheel. The combined steady and variable stress diagram is plotted using mean stress correction theory. The von-Mises stress and deformations are increased with fatigue load, and the safety factor decreases with increasing of fatigue load. The fatigue life is decreased with increasing of fatigue load. The maximum stresses are developed at wheel hub inner diameter.

**KEYWORDS:** Aircraft wheel hub, Finite element analysis, Fatigue analysis, Magnesium Alloy.**INTRODUCTION**

The major engineering factors influencing the aircraft wheel are impact load, vibration and weight of the vehicle. Under varying load, the wheel will subject to fatigue. Fatigue fracture is cyclical stresses on the material, which occurs as a result a process of crack nucleation and pre-existent cracks in the material. Three major wheel tests are used in wheel development and design. Those are rotating bending test, radial fatigue test, and impact test [1]. Despite the fact that most engineers and designers are aware of fatigue, and that a vast amount of experimental data has been generated on the fatigue properties of various metallic and non-metallic materials, fatigue failures of engineering components are still common[2]. P. Ramamurty Raju [3&4] presents the generation of the S-N curve for aluminum alloy (Al), estimation of fatigue life under radial fatigue load and bending load of cornering fatigue test using finite element analysis. The fatigue life of the damaged wheel is estimated using the stress life (S-N) approach [5]. The fatigue life limit factors introduced by other researchers were used to obtain the stress and fatigue reduction factors which were further used to estimate the S-N curve as the stress-life method [6-8]. A finite element based method is used to simulate the radial test of an automobile wheel. Besides the certainty of the results obtain through practical, computer aided simulation of the wheel, using ANSYS replicates the actual experiments [9&10].The premature fatigue crack initiation in the components can be attributed to defects of various types introduced mostly inadvertently in various stages of component design, manufacture, maintenance, inspection, operation, etc [9-12]. A large number of such failures have been investigated in the authors' laboratory over the past many years. In the present work an attempt has been made to conduct fatigue analysis of aircraft wheel hub subjected to different loads.

**FATIGUE ANALYSIS OF AIRCRAFT WHEEL HUB**

Aircraft landing gear parts are subjected to fatigue loads and it develops repeated stresses. The surface finish factor, size factor, load factor, reliability factor and miscellaneous factors have an effect on the fatigue limit of a material. The specimens are assumed to be smooth and not considered the effect of fatigue limit modifying factors.

**Dimensions and Profile of Wheel Hub:**

Wheel hub flange outer diameter (O.D)

(R1): 90.17 mm

Wheel rim O.D (R2): 73.36 mm

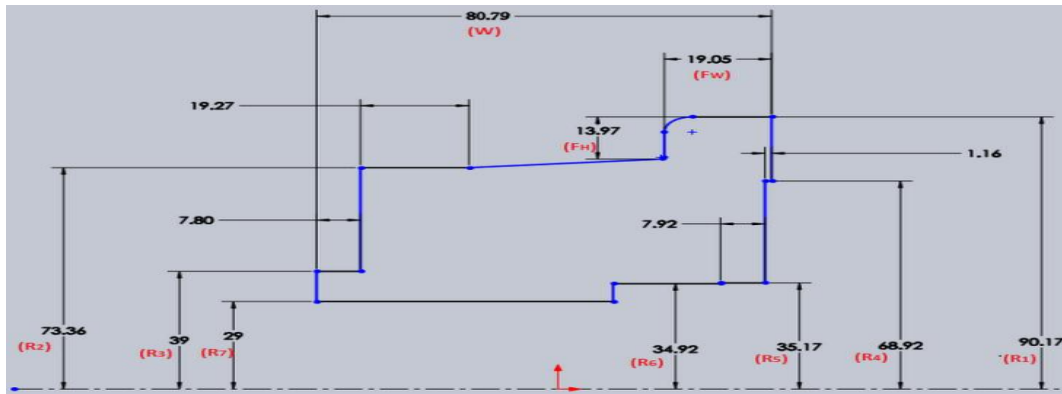
Wheel hub O.D (R3):39 mm

Wheel hub flange inner diameter (I.D)

(R4): 68.92 mm

Wheel rim I.D (R5):35.17 mm

Wheel hub I.D (R6): 34.92 mm  
 Wheel hub I.D (R7):29 mm  
 Flange height (FH): 13.97 mm  
 Wheel hub width (W): 80.79 mm Flange width (FW): 19.05 mm



**Fig.1 Profile of wheel hub**

**Mechanical Properties of Material**

**Table1. Properties of Magnesium alloy (AM60)**

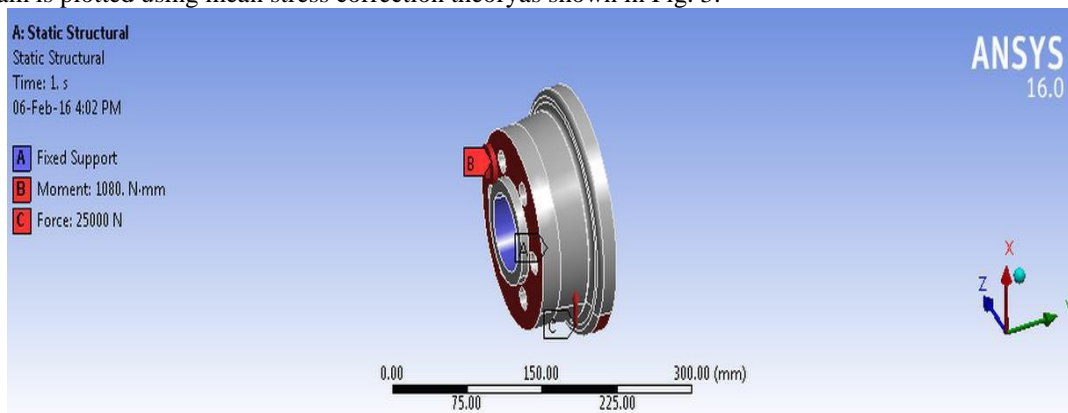
Type of material	Young's Modulus (GPa)	Poisson's ratio(v)	Density Kg/m <sup>3</sup>	Yield strength(MPa)	Ultimate tensile strength (MPa)
Magnesium alloy(AM60)	43	0.35	1790	103	224

**Table2. Alternating stress values for various number of cycles of Magnesium alloy (AM60) [6]**

Number of cycles	25000	50000	80000	10 <sup>5</sup>	10 <sup>7</sup>
Alternating stress (MPa)	107	89	84	82	82

**Modelling and Boundary Conditions**

The Magnesium alloy aircraft wheel hub is modelled using CATIA software. This 3D model is converted into an IGES file then imported into ANSYS. The element size is 3 mm and shape of elements is program controlled. The centre of the wheel hub is fixed (all degrees of freedom arrested).The constant amplitude load (fully reversed) and moments are applied to the aircraft wheel hub as shown in Fig.2. The radial fatigue test conditions are applied to aircraft wheel in Finite element software and fatigue analysis is done.The combined steady and variable stress diagram is plotted using mean stress correction theoryas shown in Fig. 3.



**Fig.2 Boundary conditions of wheel hub**

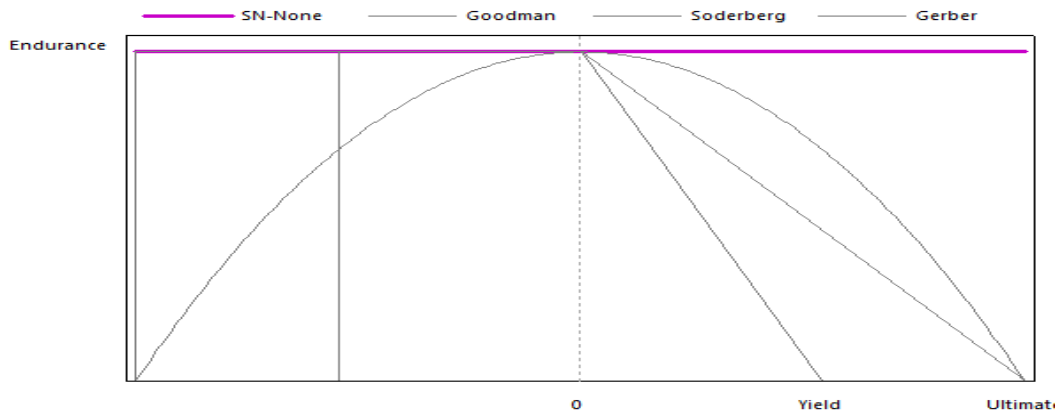


Fig.3 Mean stress correction theory

RESULTS AND DISCUSSION

The following numerical examples give an insight into and clarify the safety and fatigue life of wheel hub. The numerical examples are presented to analyze the load bearing capacity and failure load of the aircraft wheel hub.

Wheel Hub Analysis of Magnesium Alloy (AM60)

**Numerical Example 1:** Fatigue load (35000N) and moment (1080 N-m) are applied to the aircraft wheel hub. The maximum equivalent (von-Mises) stress, maximum deformation, minimum safety factor and minimum fatigue life of wheel hub are obtained from ANSYS software. These values are extracted from Fig.4 to Fig 7 respectively, and tabulated in table 3.

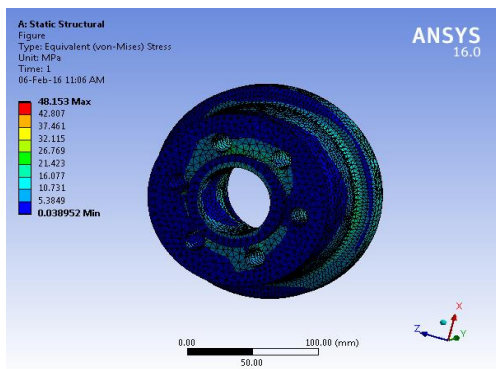


Fig.4 von-Mises stress at the wheel hub

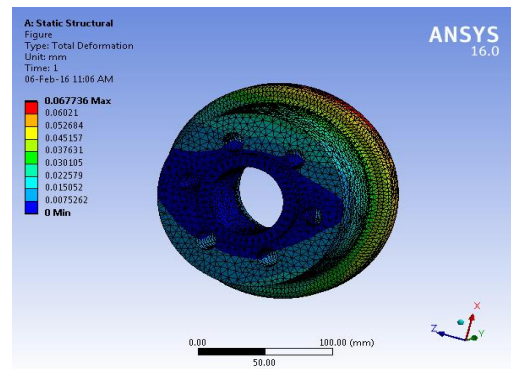


Fig.5 Deformation of wheel hub

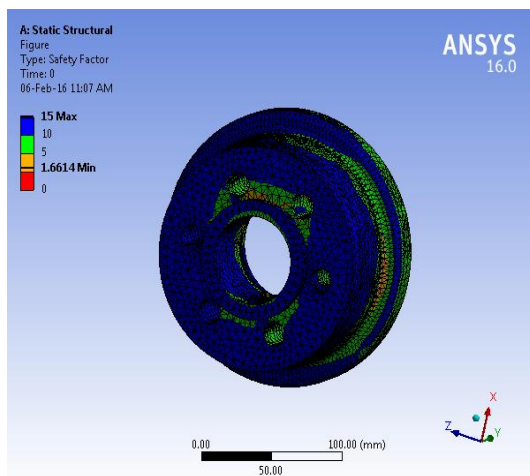


Fig.6 Safety factor of wheel hub

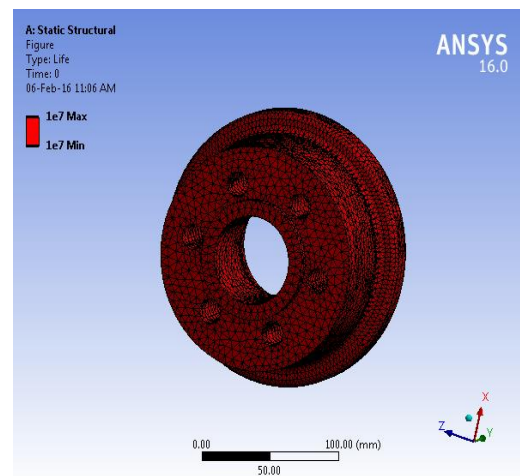
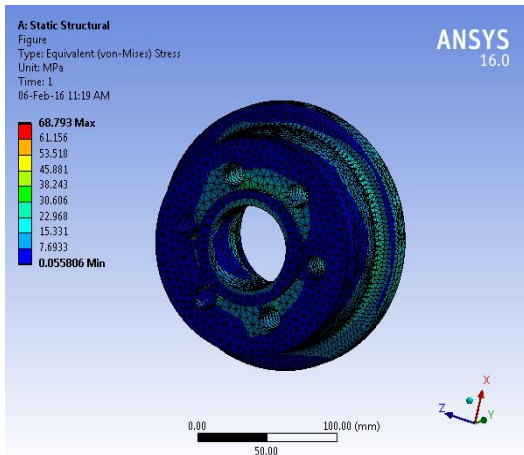
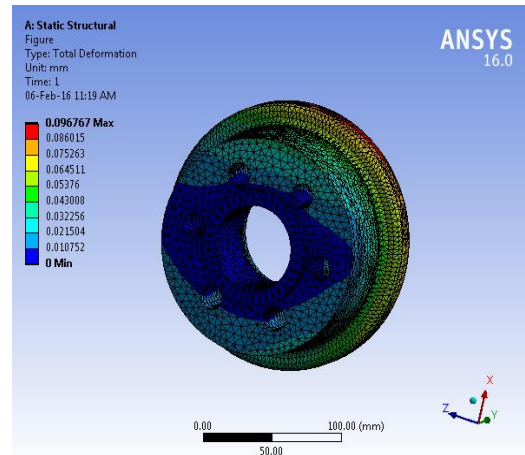


Fig.7 Fatigue life of wheel hub

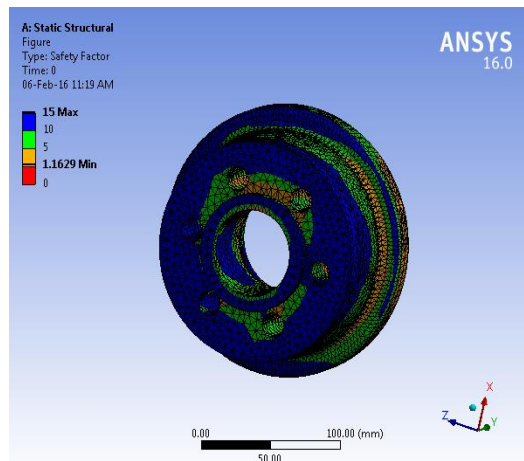
**Numerical Example 2:** Fatigue load (50000N) and moment (1080N-m) are applied to the aircraft wheel hub. The maximum equivalent (von-Mises) stress, maximum deformation, minimum safety factor and minimum fatigue life of wheel hub are obtained from ANSYS software. These values are extracted from Fig.8 to Fig.11 respectively, and tabulated in table 3.



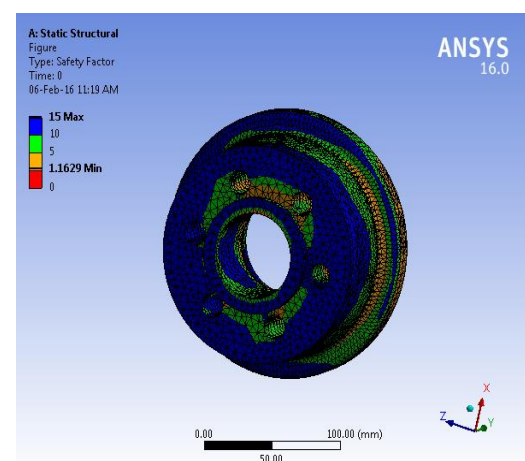
**Fig.8 von-Mises stress at the wheel hub**



**Fig.9 Deformation of wheel hub**

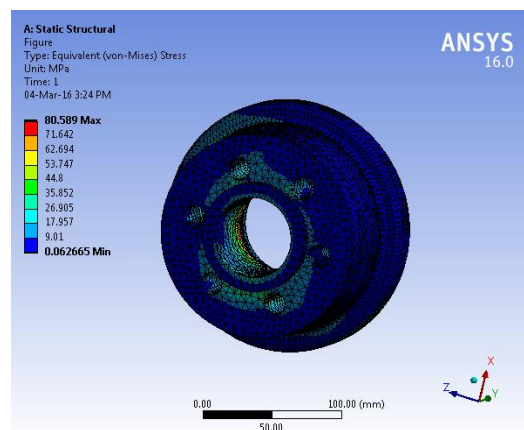


**Fig.10 Safety factor of wheel hub**

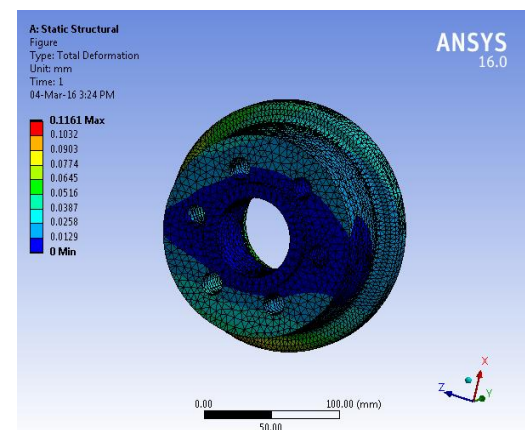


**Fig.11 Fatigue life of wheel hub**

**3.1.3 Numerical Example 3:** The fatigue analysis process is repeated for various loads and the failure occurs at 60,000N (approximately). The maximum equivalent (von-Mises) stress, maximum deformation, minimum safety factor and minimum fatigue life of wheel hub at 60,000N are extracting from Fig.12 to Fig 15 respectively and tabulated in table 3.



**Fig.12 von-Mises stress at the wheel hub**



**Fig.13 Deformation of wheel hub**

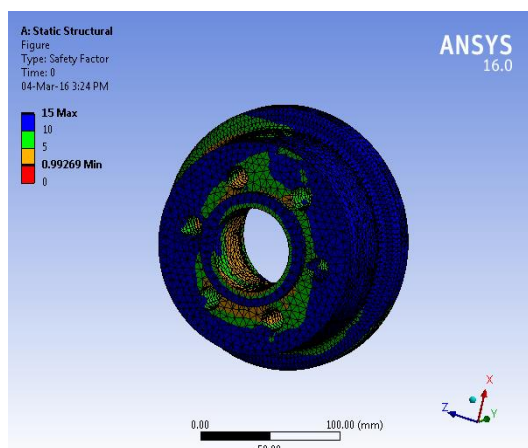


Fig.14 Safety factor of wheel hub

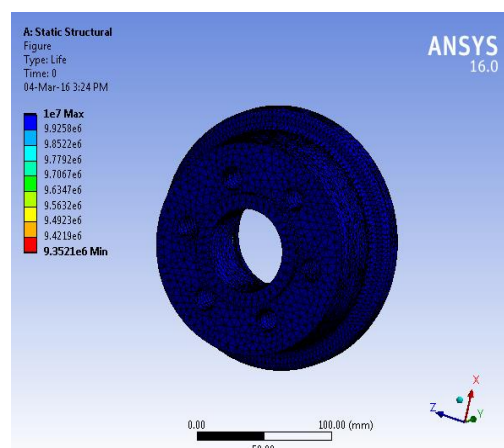


Fig.15 Fatigue life of wheel hub

Table3. Results of fatigue analysis at different loads of a Magnesium alloy (AM60)

Material	Load (N)	Deformation (mm)	von-Misses stress(Mpa)	Fatigue life (cycles)	Safety factor
Magnesium alloy(AM60)	35000	0.0677	48.153	10 <sup>7</sup>	1.601
	50000	0.0967	68.793	10 <sup>7</sup>	1.1629
	60000	0.1161	80.589	9.35x10 <sup>6</sup>	0.992

The maximum deformation and maximum equivalent (von-Misses) stress are increased with fatigue load and safety factor is decreased. The fatigue life is decreased with increasing of fatigue load. The Magnesium alloy is failing around 60000N. The maximum stresses are developed at wheel hub inner diameter.

**CONCLUSION**

The finite element fatigue analysis has been carried out on the aircraft wheel hub using ANSYS software. The magnesium alloy is considered in the present work. The various load conditions are applied on wheel hub. The fatigue life, von-Misses stress, deformation, fatigue life and safety factor are obtained from ANSYS software for each load condition on both materials. The combined steady and variable stress diagram is plotted using mean stress correction theory. The von-Misses stress and deformation are increased with fatigue load. The fatigue life and safety factor are decreasing with increasing of fatigue load.

**REFERENCES**

- [1] Hsu YL, Wang SG and Liu TC, “Prediction of fatigue failure of aluminum disc wheel using the failure probability contour based on historical test data” in J Chin Inst Industrial Eng., vol. 21, no. 6, pp.551–558, 2004.
- [2] Hsu YL and Hsu MS, “Weight reduction of aluminum disc wheels under fatigue constraints using a sequential neural network approximation method” in Computers Ind., vol. 46, no. 2, pp. 61–73, 2001.
- [3] P. Ramamurthy Raju, B. Satyanarayana, K. Ramji and K. Suresh Babu, “Evaluation of fatigue life of aluminum alloy wheels under radial loads” in Engineering Failure Analysis., vol. 14, no. 5, pp. 791-800, 2007.
- [4] P. Ramamurthy Raju, B. Satyanarayana, K. Ramji and K. Suresh Babu, “Evaluation of fatigue life of aluminium alloy wheels under bending loads” in Fatigue & Fracture of Engineering Materials & Structures., vol. 32, no. 2, pp. 119-126, 2009.
- [5] M.M Topac, S Ercan, and N S Kuralay, “Fatigue life prediction of a heavy vehicle steel wheel under radial loads by using finite element analysis” in Engineering Failure Analysis., vol. 20, no. 3, pp. 67-79, 2012.
- [6] Md S Bhuiyan, Y Mutoh, Y Miyashita, Y Ostuka and T Koike, “Notch effect on fatigue strength of die cast AM60 magnesium alloy” in Asian Pacific Conference for Materials and Mechanics, Yokohama, Japan, November 13-16, 2009.
- [7] S C Kerr, D L Russell, U S Patel and N M W Bishop, “Fe-based wheel fatigue analysis using MSC.fatigue” in 1ST MSC Worldwide Automotive Conference., Munich, Germany, September 20-22, 1999.
- [8] Hua Sun, “Optimization design of the composite hub connection structure based on ANSYS software technology” in Advanced Materials Research., vol. 139, no. 10, pp. 1068-1072, 2010.

- [9] L Wang, Y Chen, C Wang and O Wang, “Fatigue life analysis of aluminium wheels by simulation of rotary fatigue test” in *Journal of Mechanical Engineering.*, vol. 57, no. 1, pp. 31-39, 2011.
- [10] S K Bhaumik, M Sujata and M A Venkataswamy, “Fatigue failure of aircraft components” in *Engineering Failure Analysis.*, vol. 15, no. 6, pp. 675-694, 2008.
- [11] Minh Phong Luong “Fatigue limit evaluation of metals using an infrared thermographic technique” in *Mechanics of Materials.*, vol. 28, no. 4, pp. 155-163, 1998.
- [12] W Song, L Woods, T Davis, J K Offutt, P Bellis, S Handler, K Sullivan and W Stone, “Failure analysis and simulation evaluation of an AL 6061 alloy wheel hub” in *Journal of Failure Analysis and Prevention.*, vol. 15, no. 4, pp. 521-533, 2015.
- [13] R.I Stephens, A. Fatemi, R.R Stephens, H.O Fuchs, A. Fatemi, “Metal fatigue in engineering” in 2nd Edition, Wiley-Interscience, 2000.
- [14] S. Zhao, Z. Wang, “Fatigue design” in *Mechanical Industrial Press*, 1997.